

El Universo EXPLOSIVO/ACTIVO (y el Cosmos/Kosmos)

S. Lipari

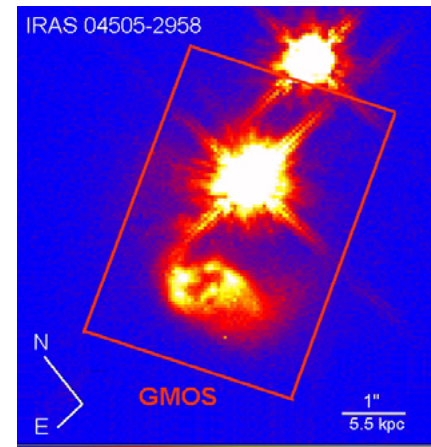

EXPLOSION: liberacion de energia/materia en forma rapida y violenta

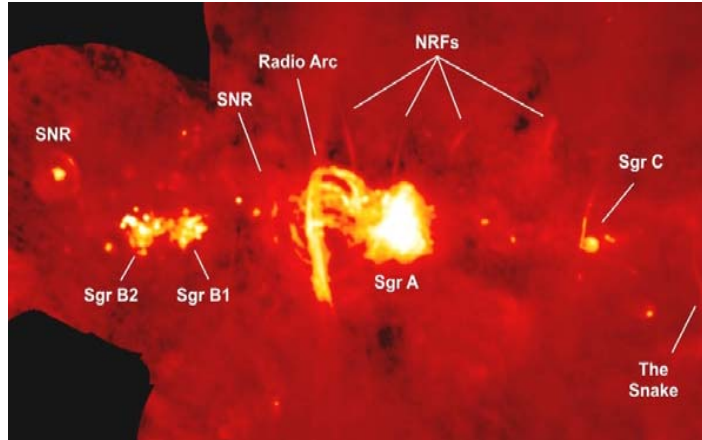
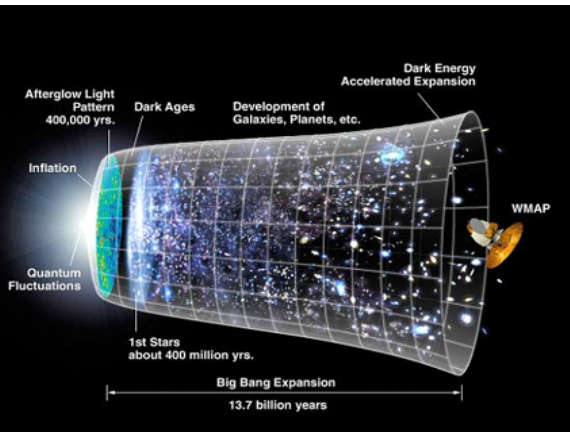
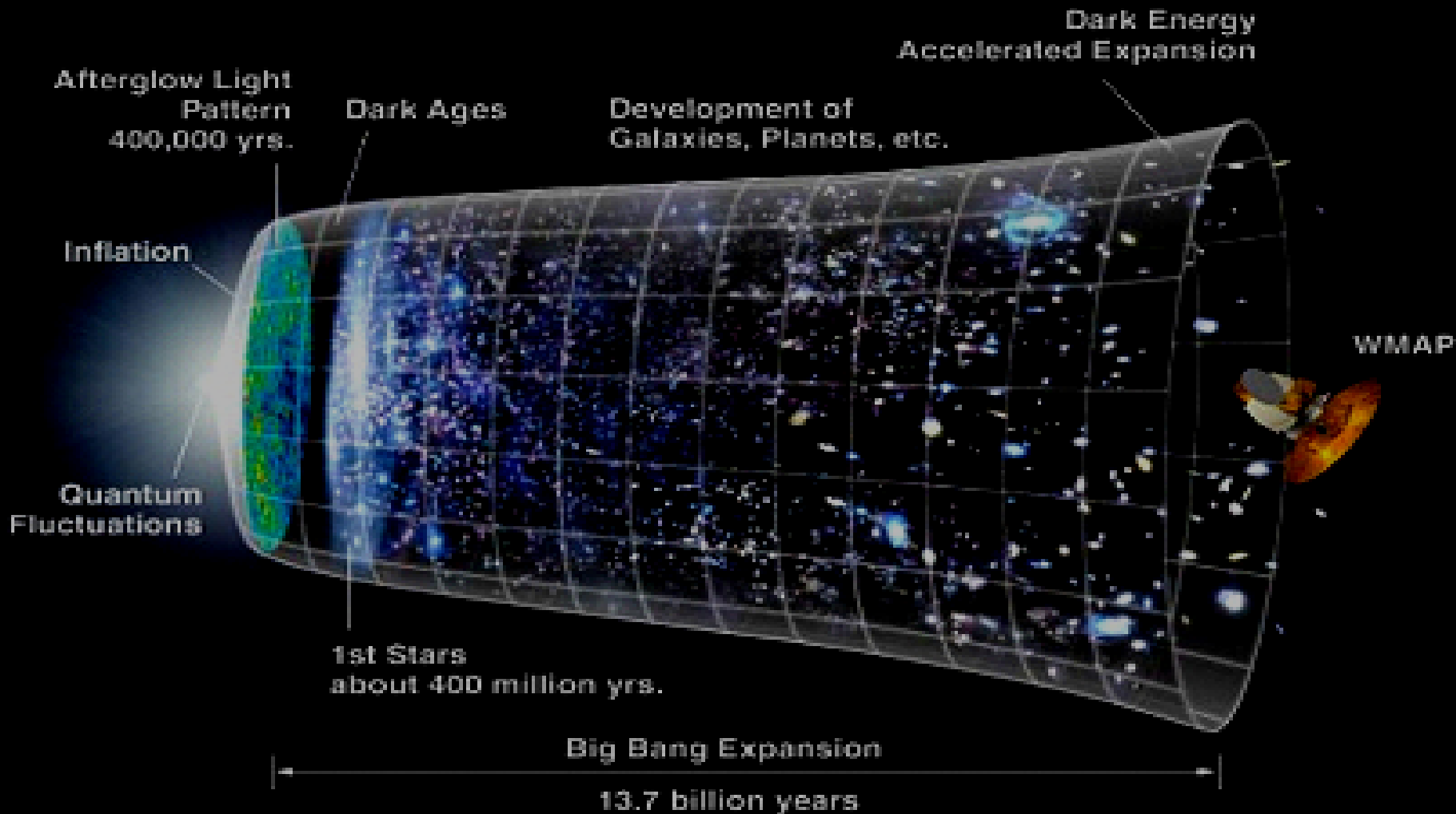

BASE de Astronomia: (1) Observacion +
(2) Teoria +
(3) Tecnica/Instrumentos

las 3 en forma integrada (F. Hoyle, R. Feynman)



Gravedad: Ejemplo de Ley Fisica

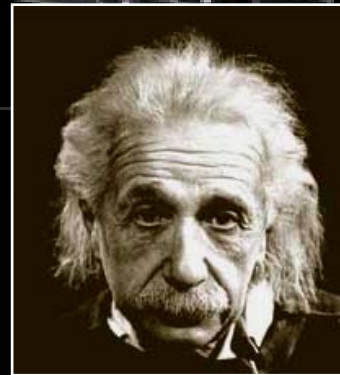
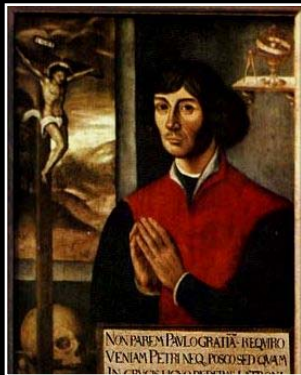

“Hemos heredado de nuestro antepasados la búsqueda de un conocimiento Unificado y Universal.



El nombre dado a las casas de altos estudios nos lo recuerda.”

E. Schrodinger (Que es la Vida?)



“Es mucho mas hermoso saber algo de todo, que saber todo de una cosa.

Esa Universalidad es lo más bello del Pensamiento.”

B. Pascal (Pensamientos)

Efecto RELAMPAGO



Efecto FOTO



Efecto BOSQUE:

Tiempo + Relaciones

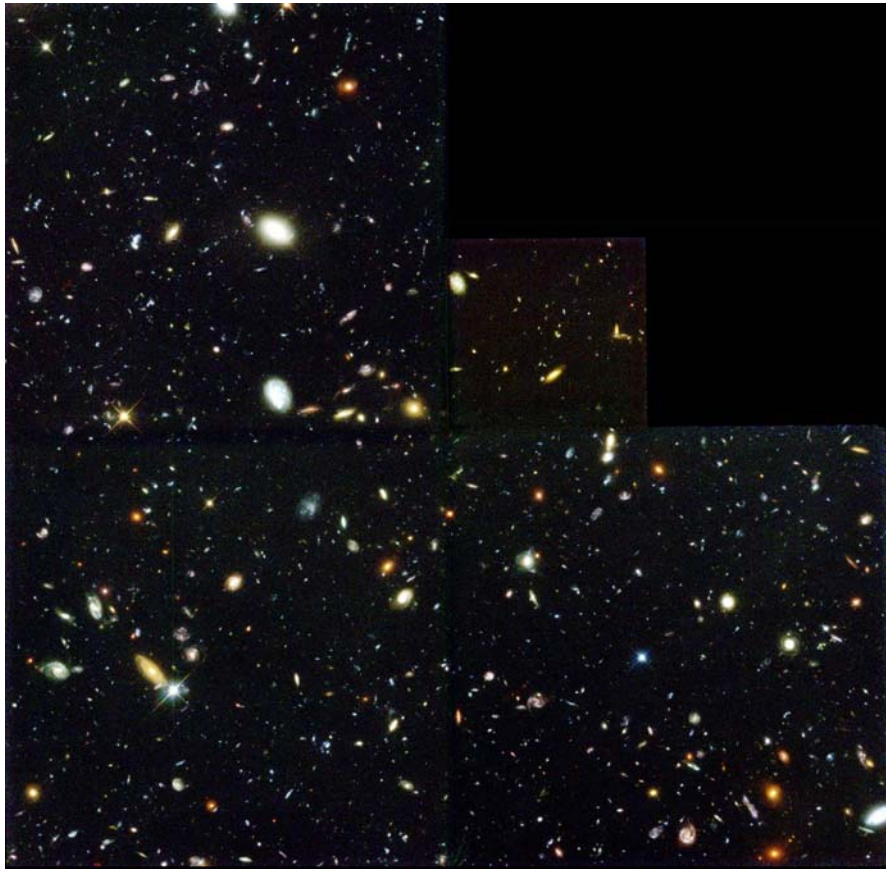

LUZ: Imágenes y Espectros

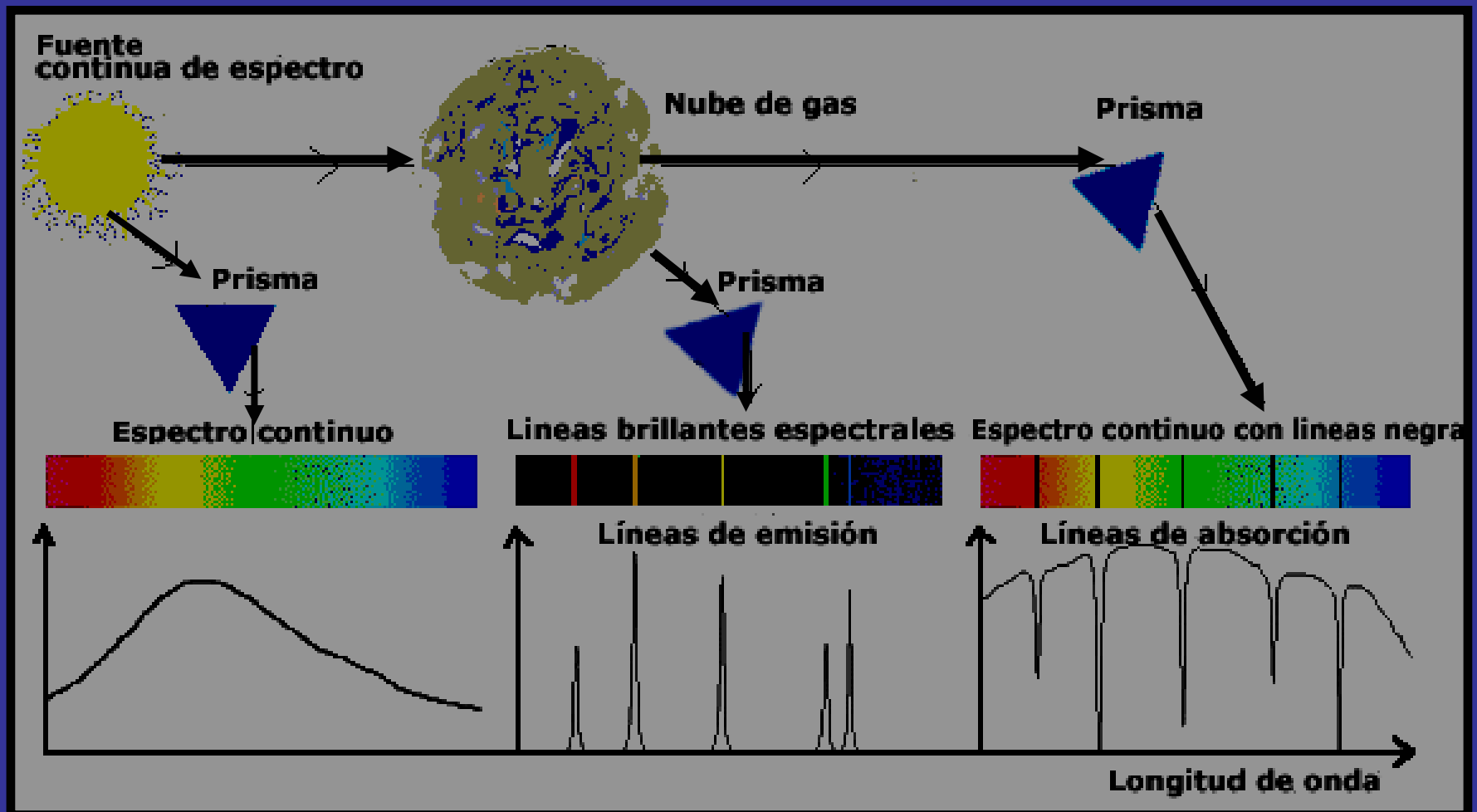

El Universo EXPLOSIVO/ACTIVO **(y el Cosmos/Kosmos)**

(I) Explosiones en la TIERRA
[colisiones, volcanes, etc]

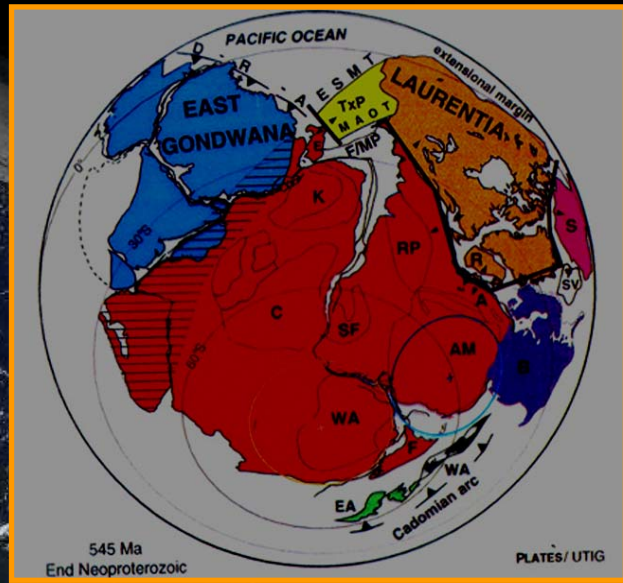
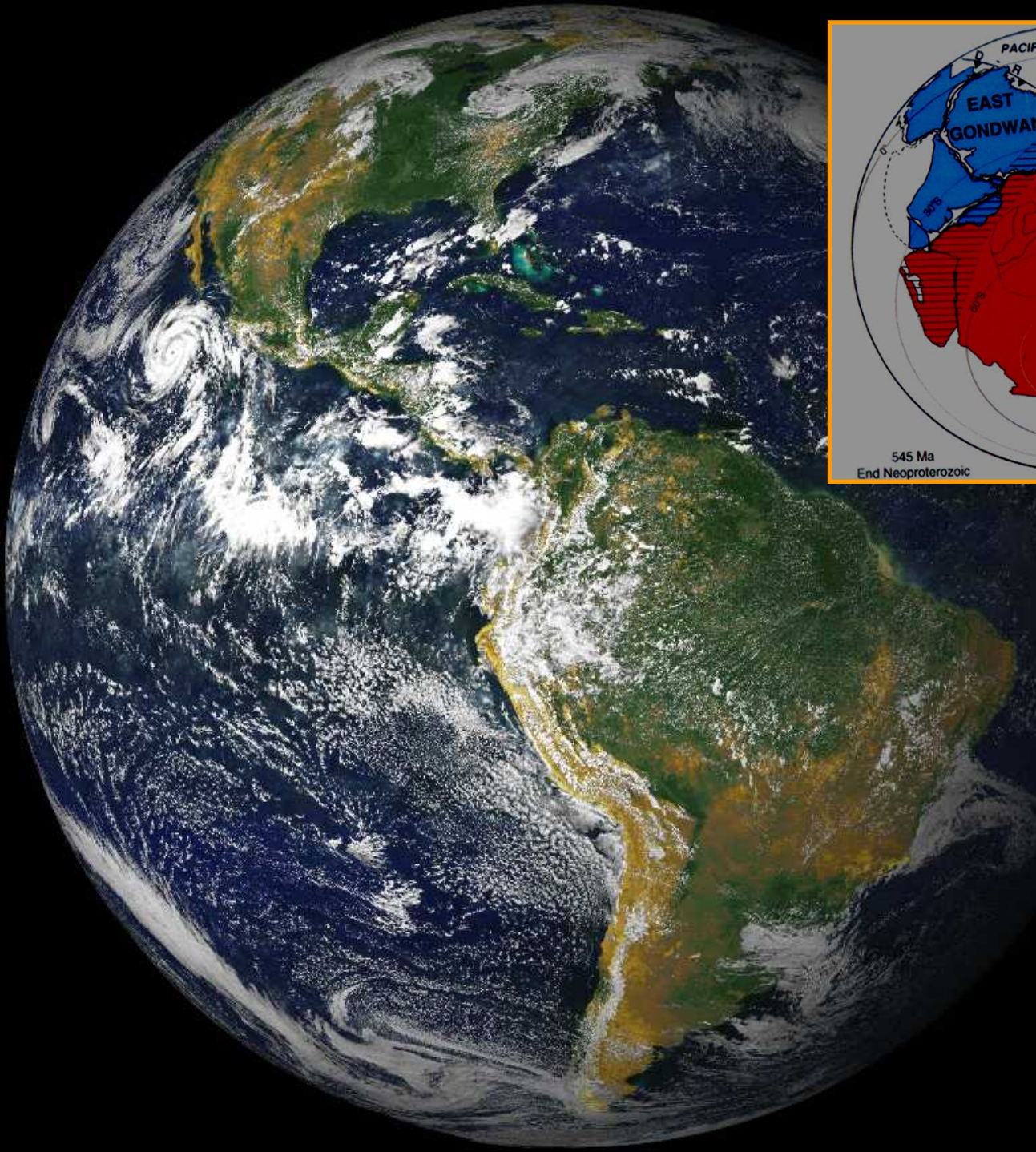



TIERRA y LUNA



Luna





Santa Elena

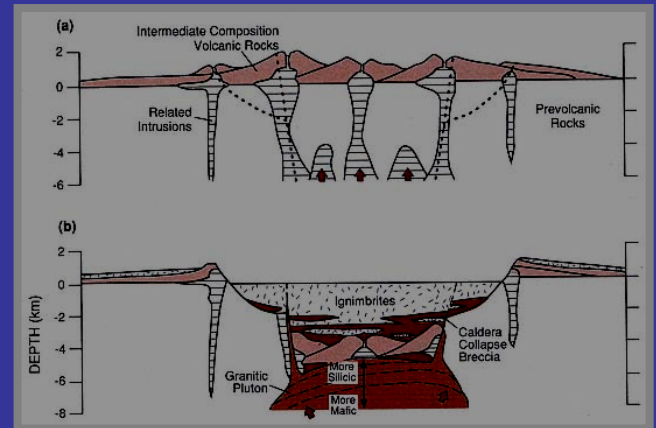
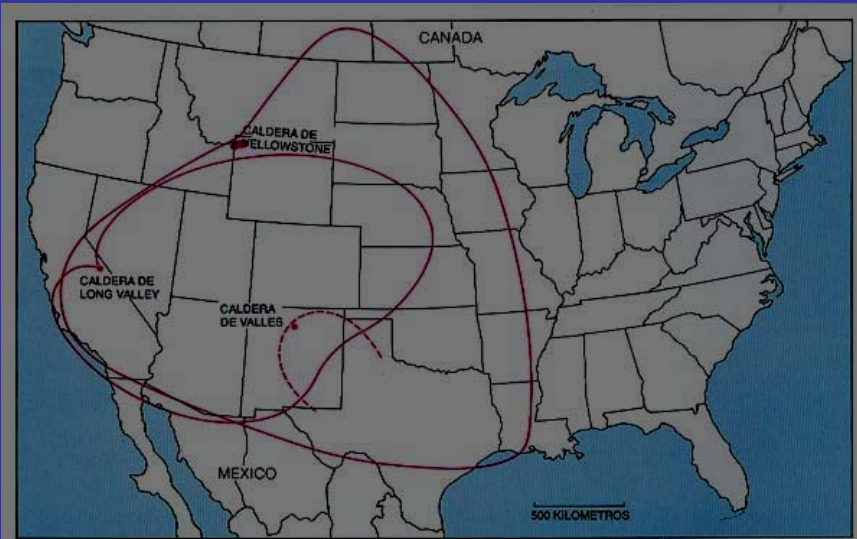
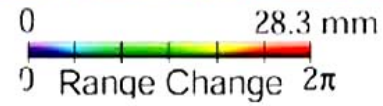
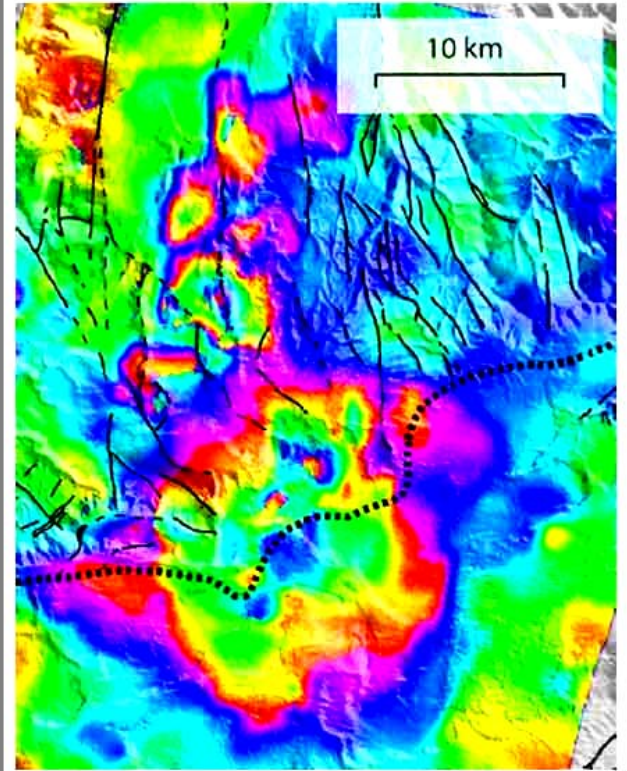

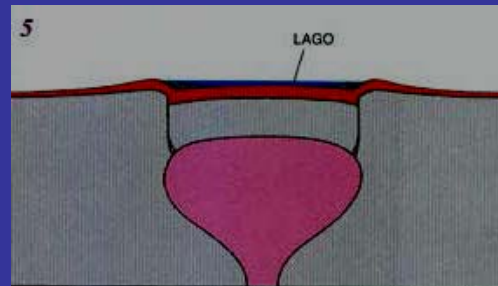
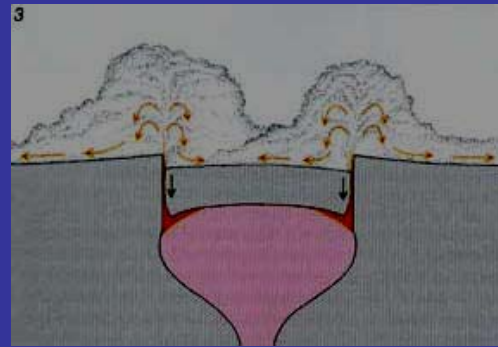
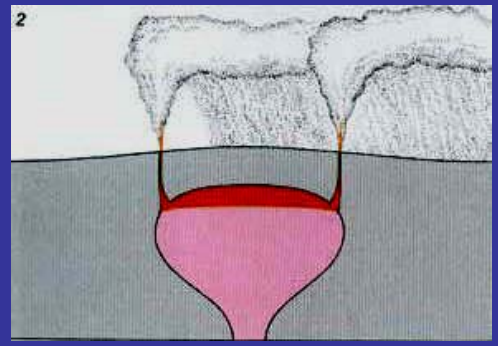
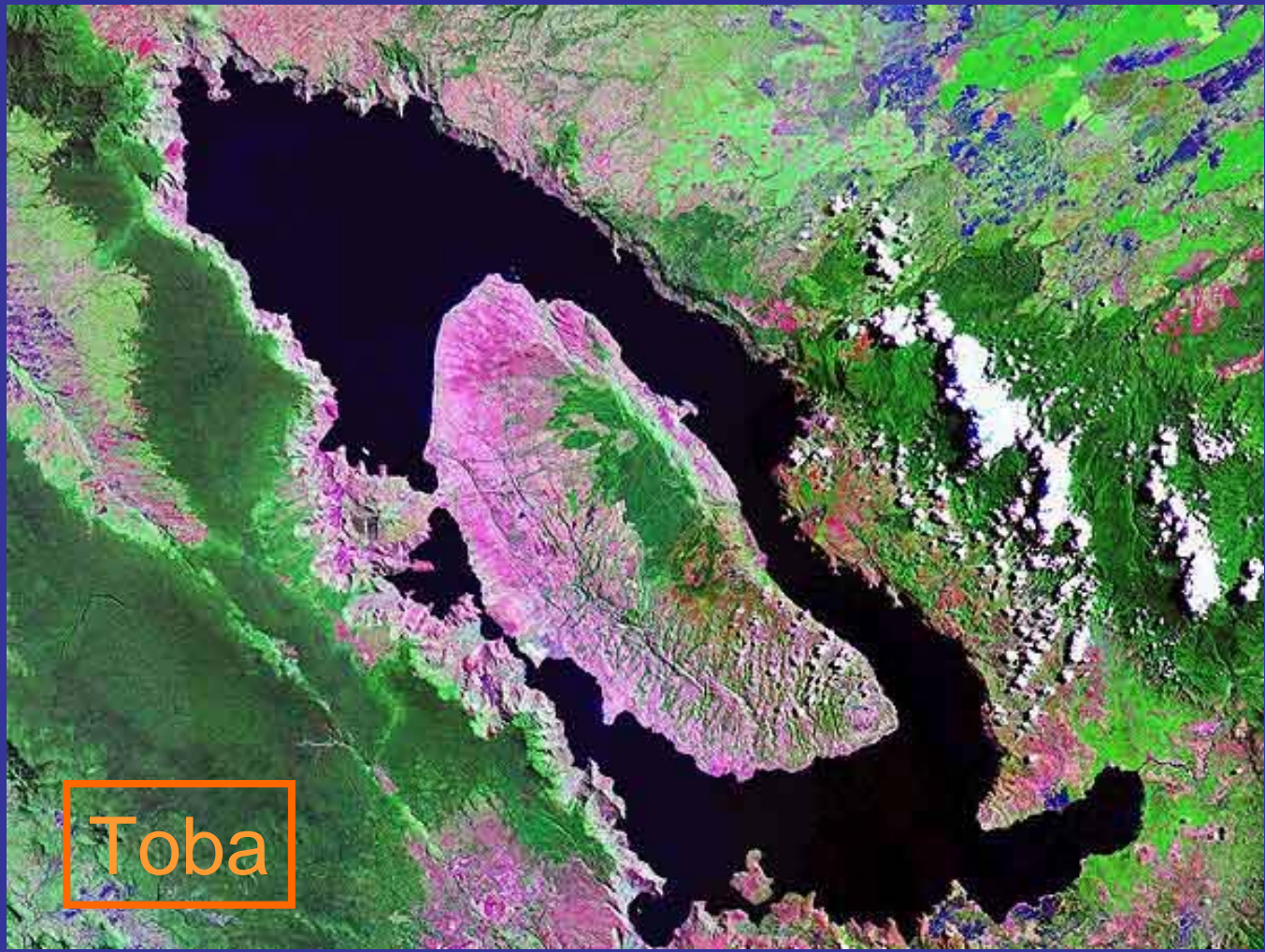



Cerro Galan

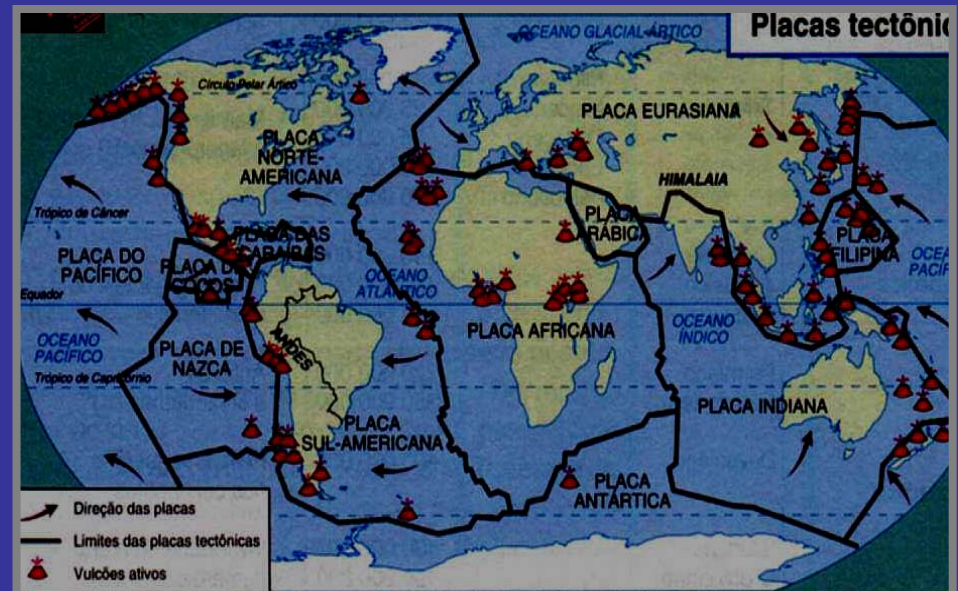
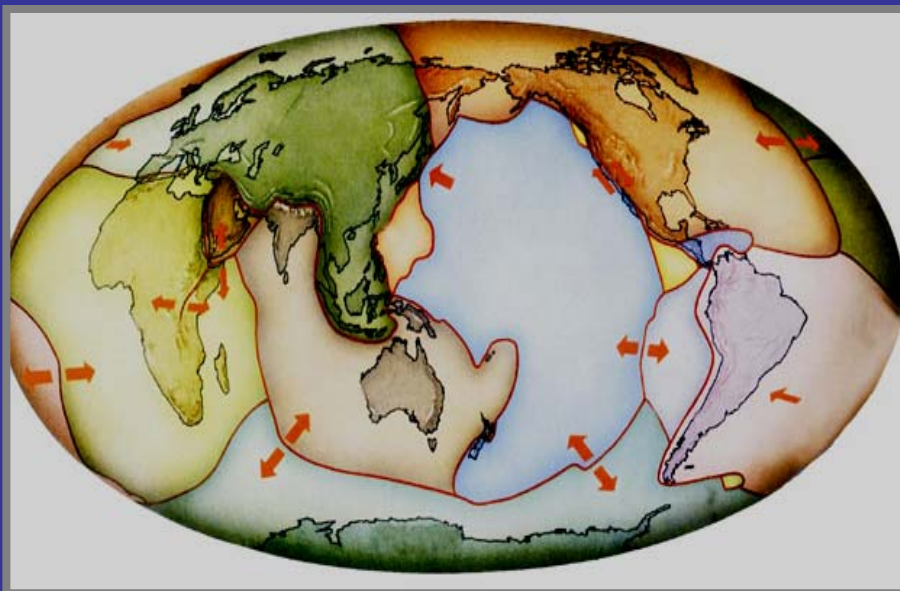
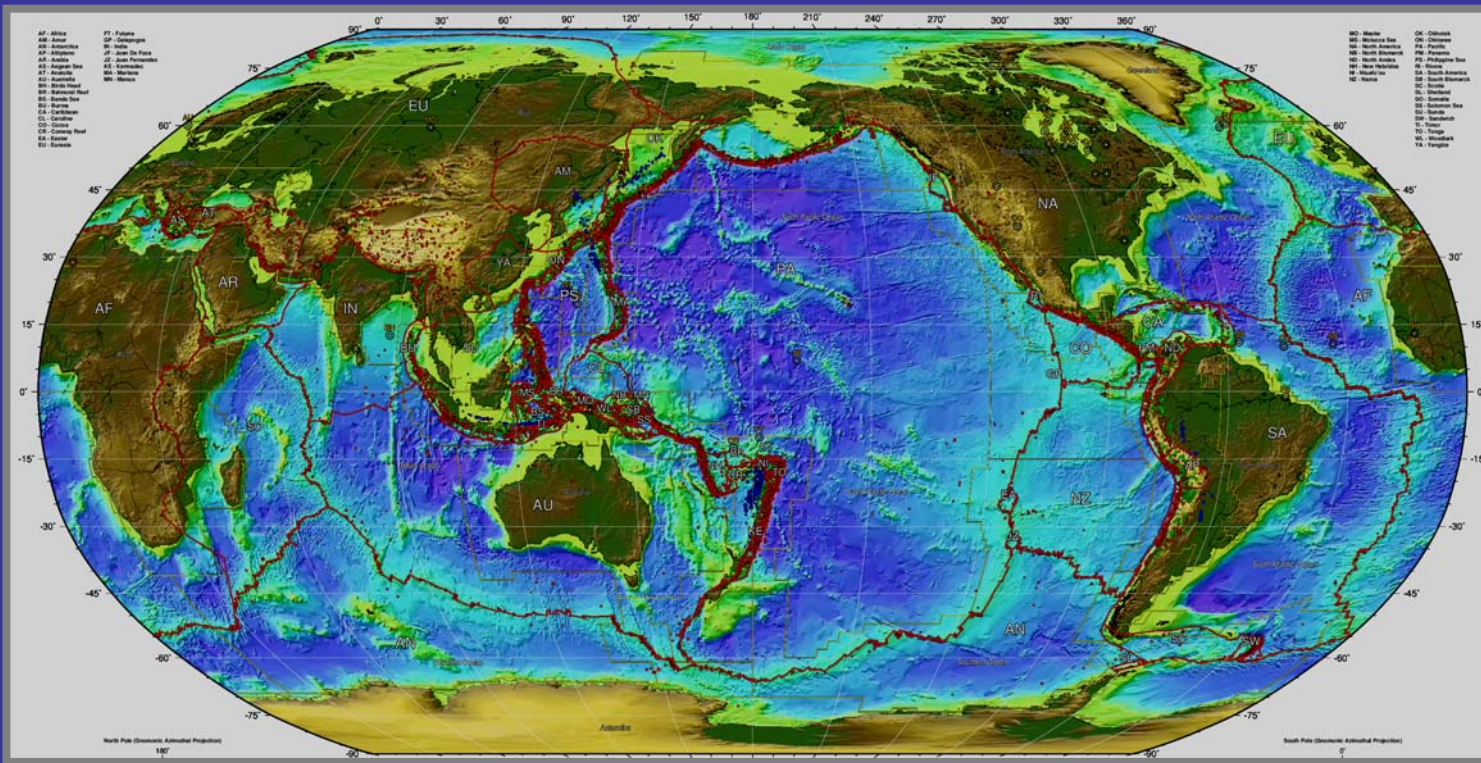

Explosión Nuclear

**“En caso de un
conflicto nuclear:**

**hasta un 50% de la
Población mundial
se podría extinguir”**

H. Reeves



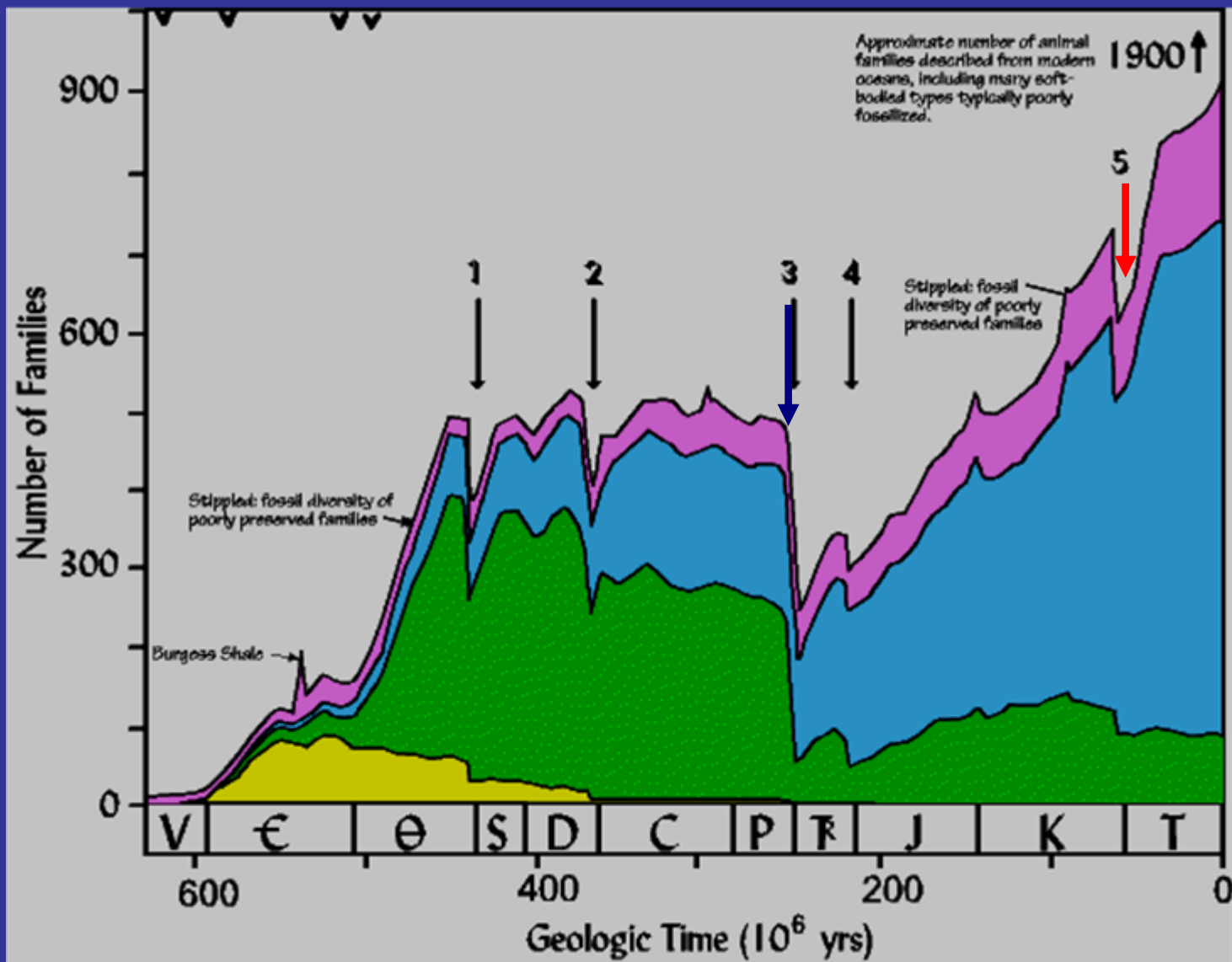

GRANDES EXTINCCIONES EN LA TIERRA
(ultimos 600 Mill. A.)

El Universo EXPLOSIVO/ACTIVO **(y el Cosmos/Kosmos)**

(II) Explosiones en el SISTEMA SOLAR

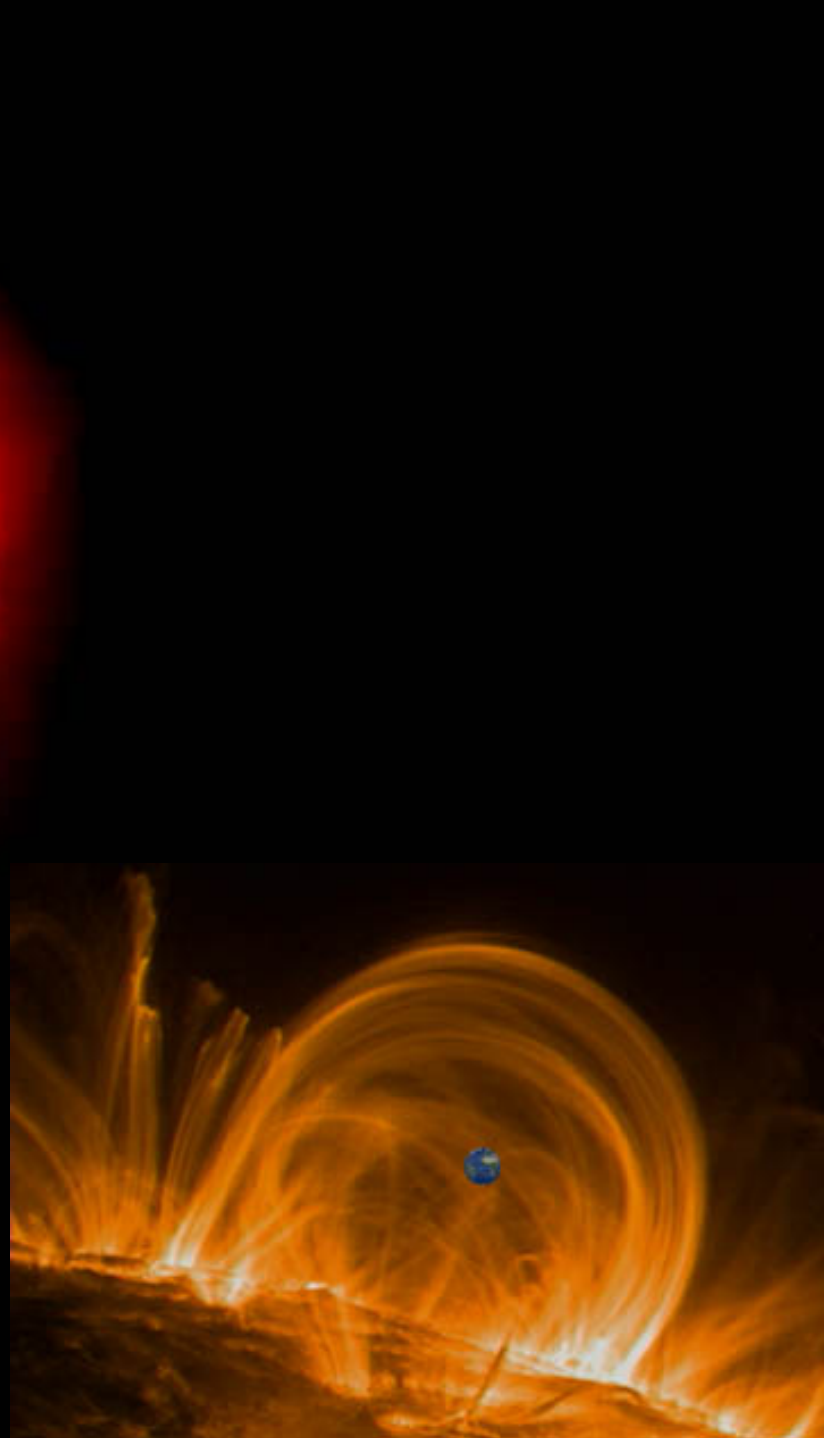
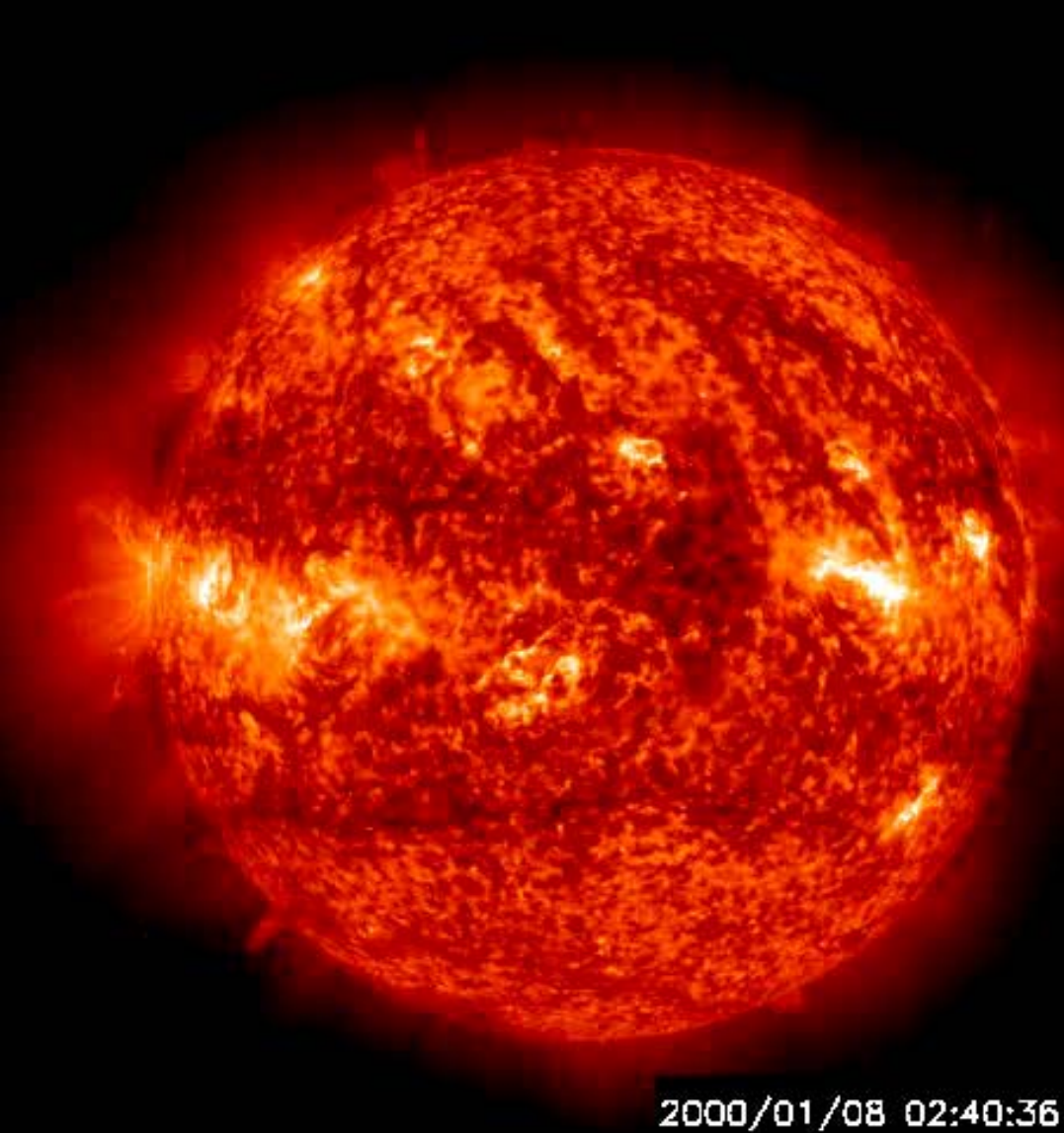

SOL (activo): a mitad de su vida

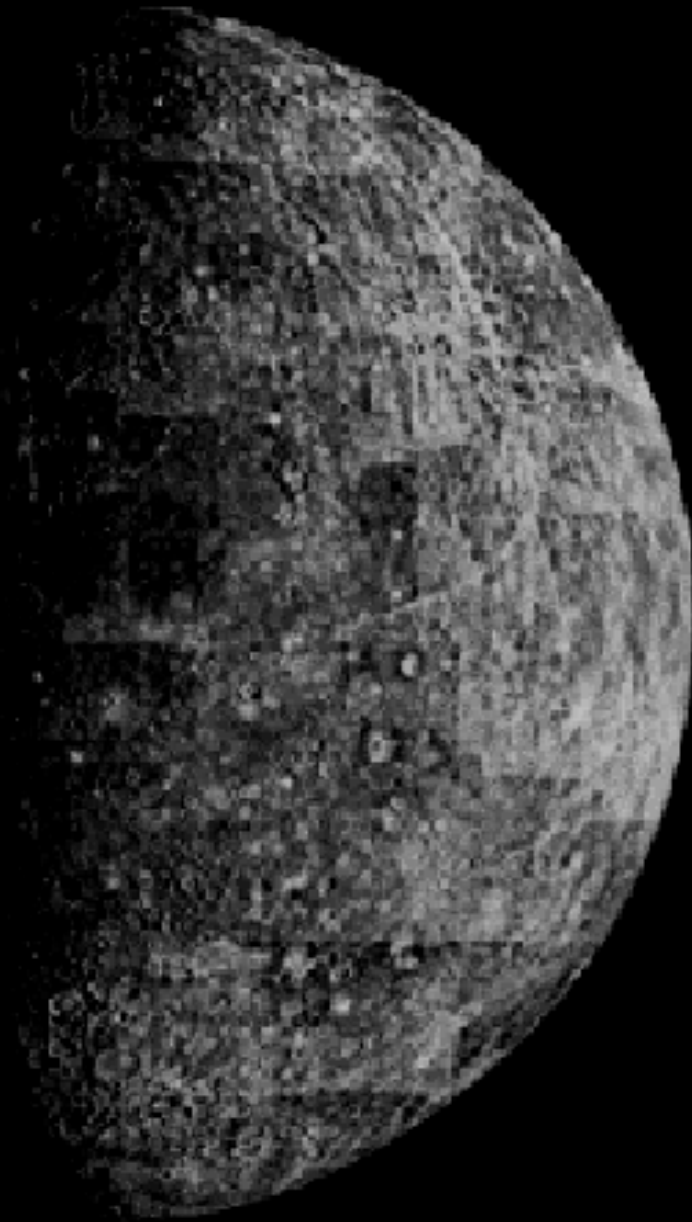

Mercurio

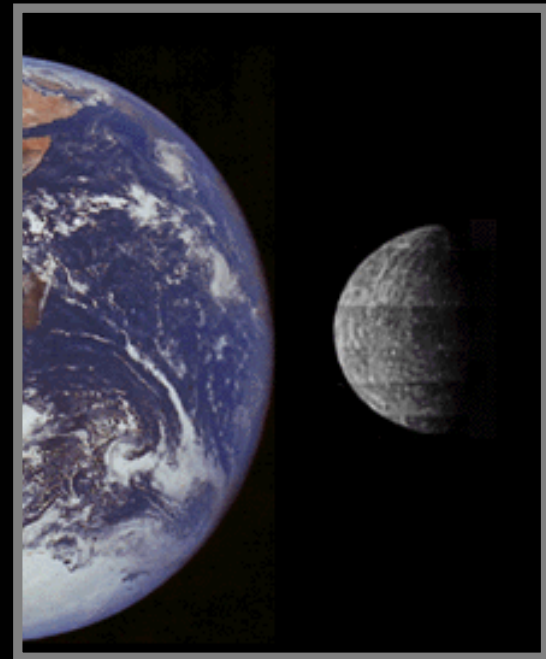

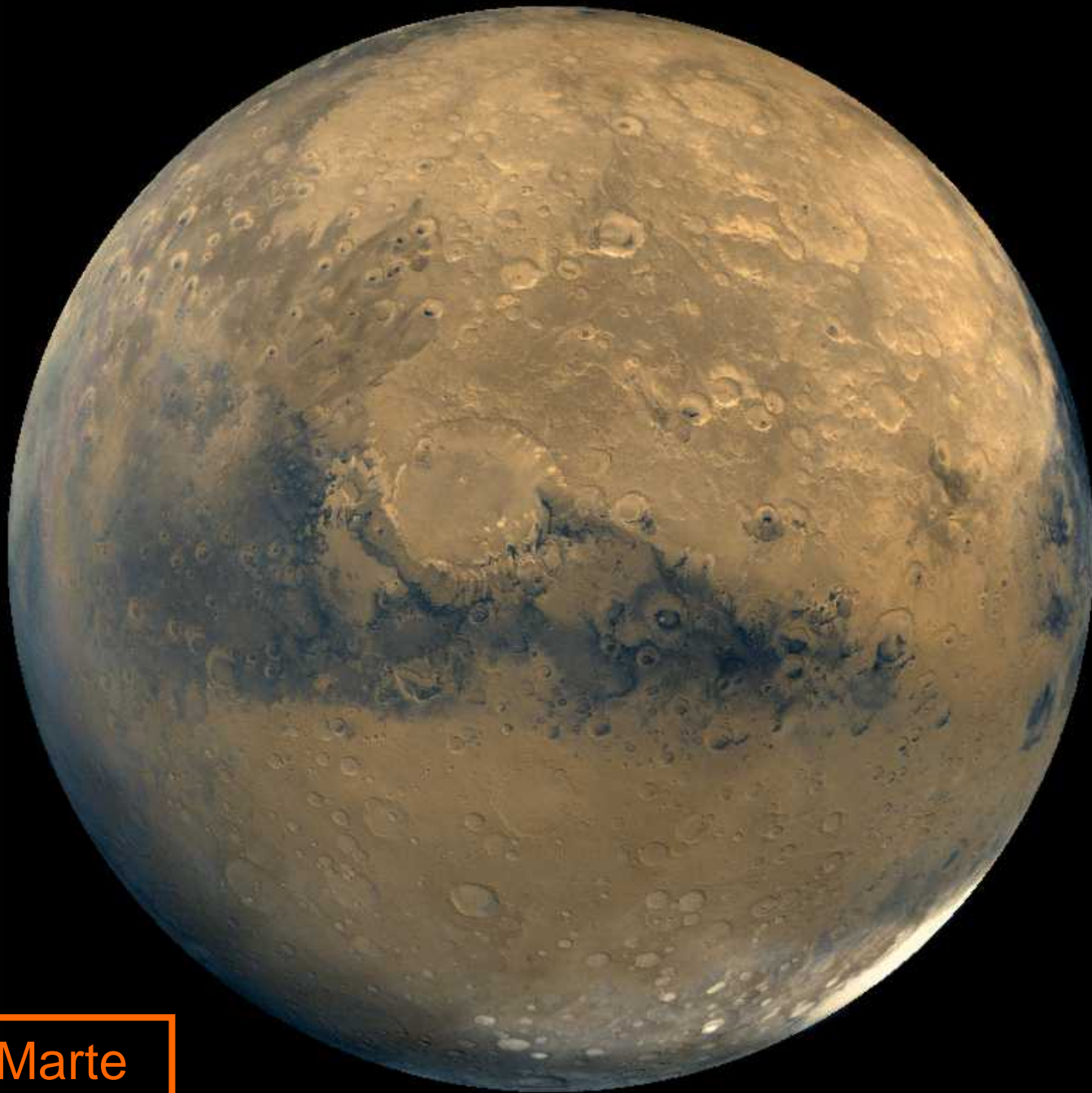

Marte

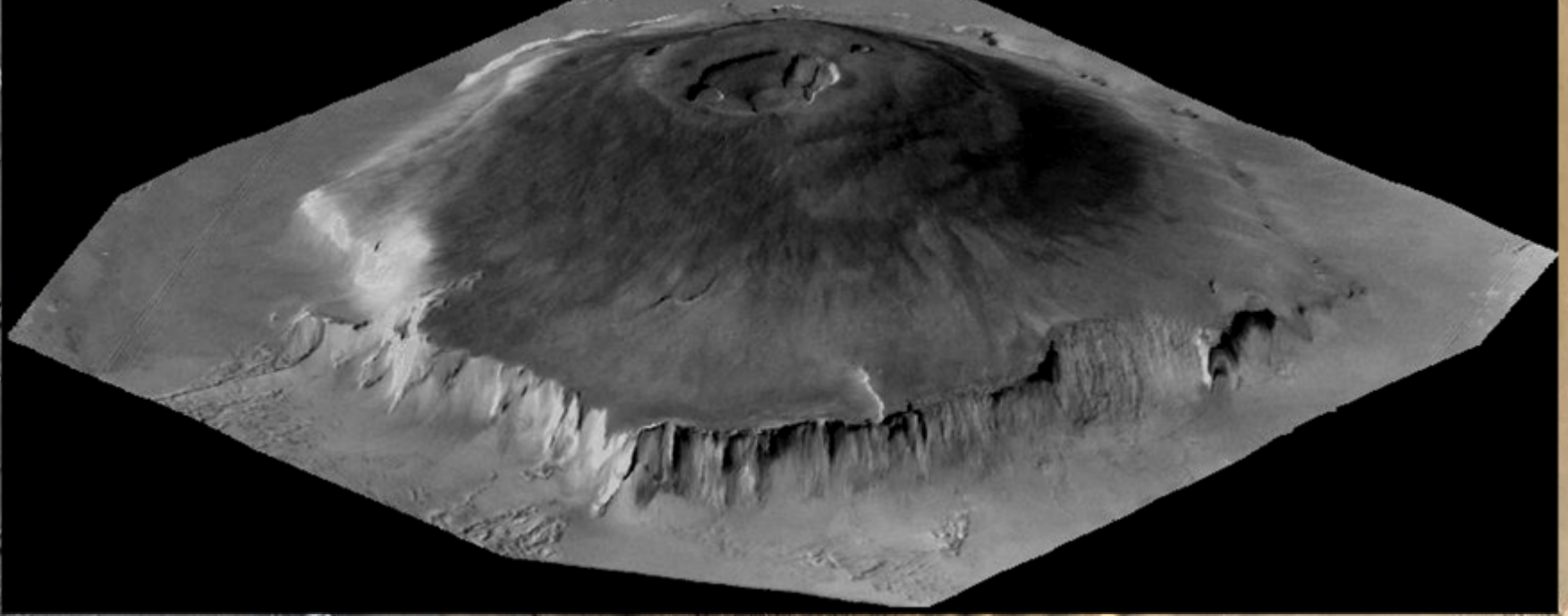

Monte Olimpo (Marte)

Explosiones por impacto de un Cometa en **Jupiter**



Impatto della cometa Levy-Shoemaker 9
su Giove



Io (satellite de Jupiter)

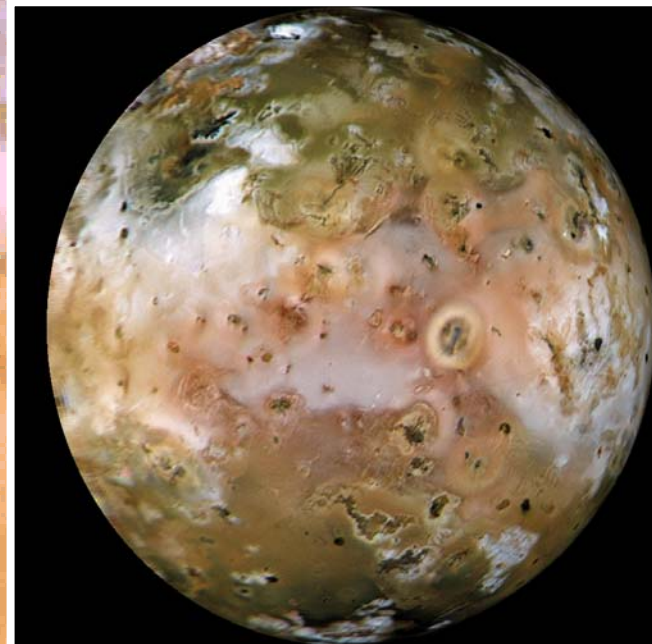
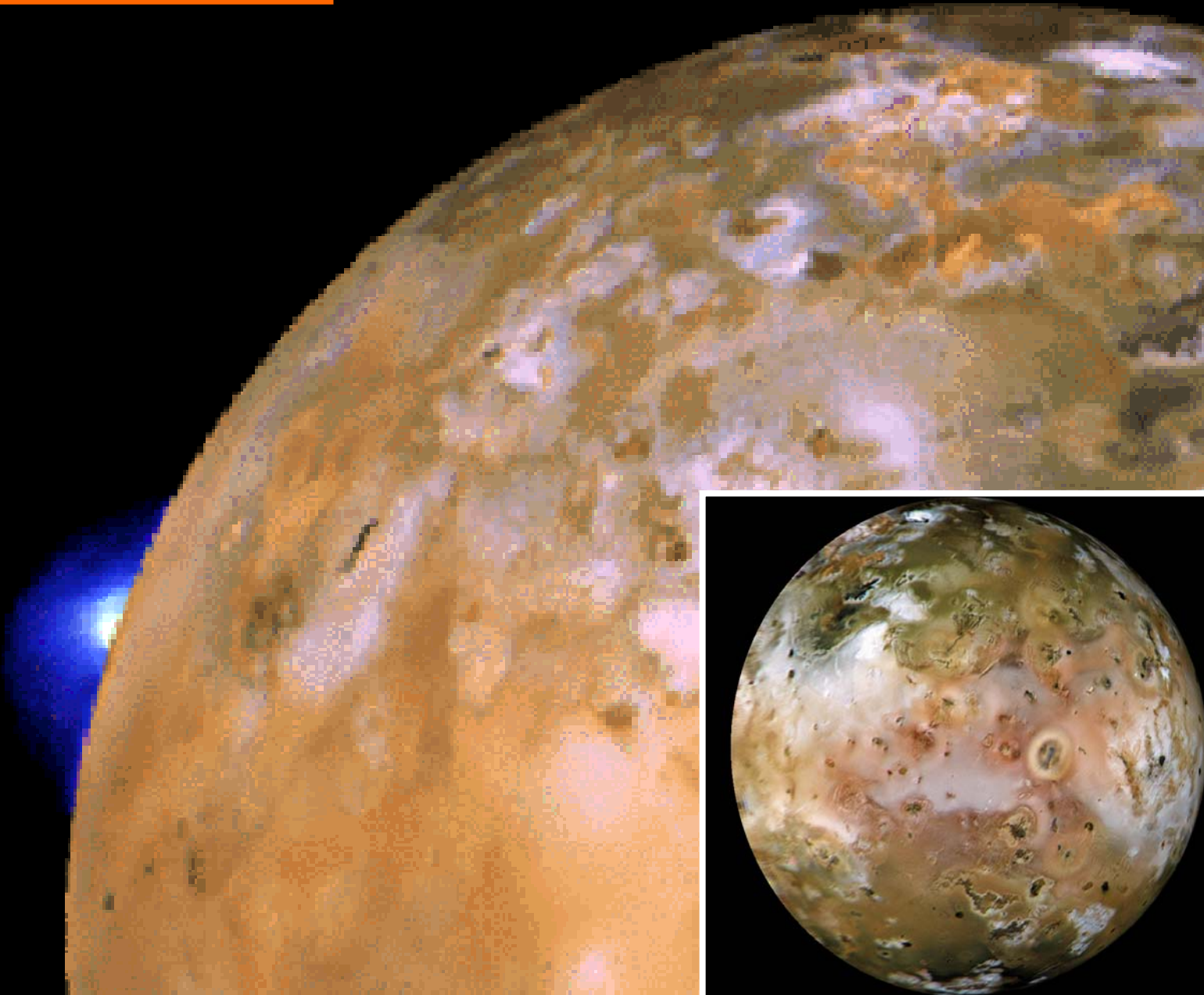

Saturno (+Dione, +Tetis)

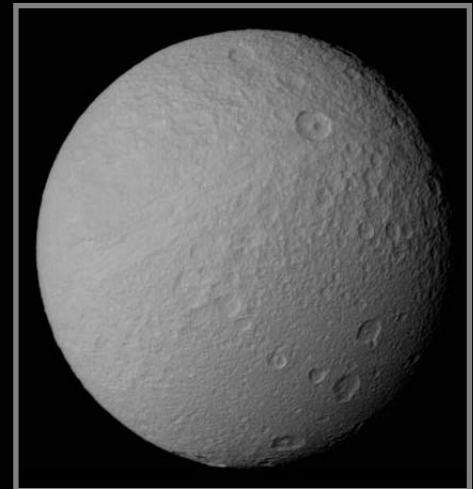
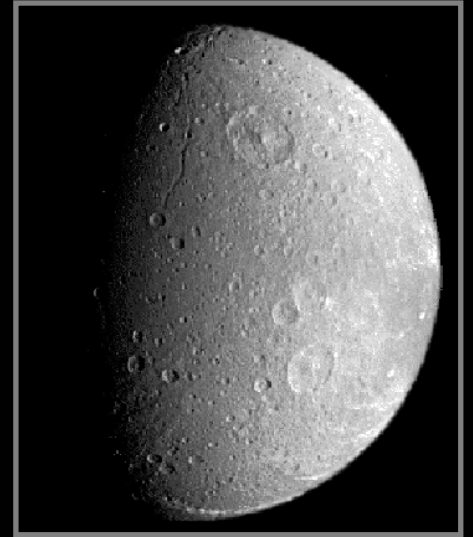
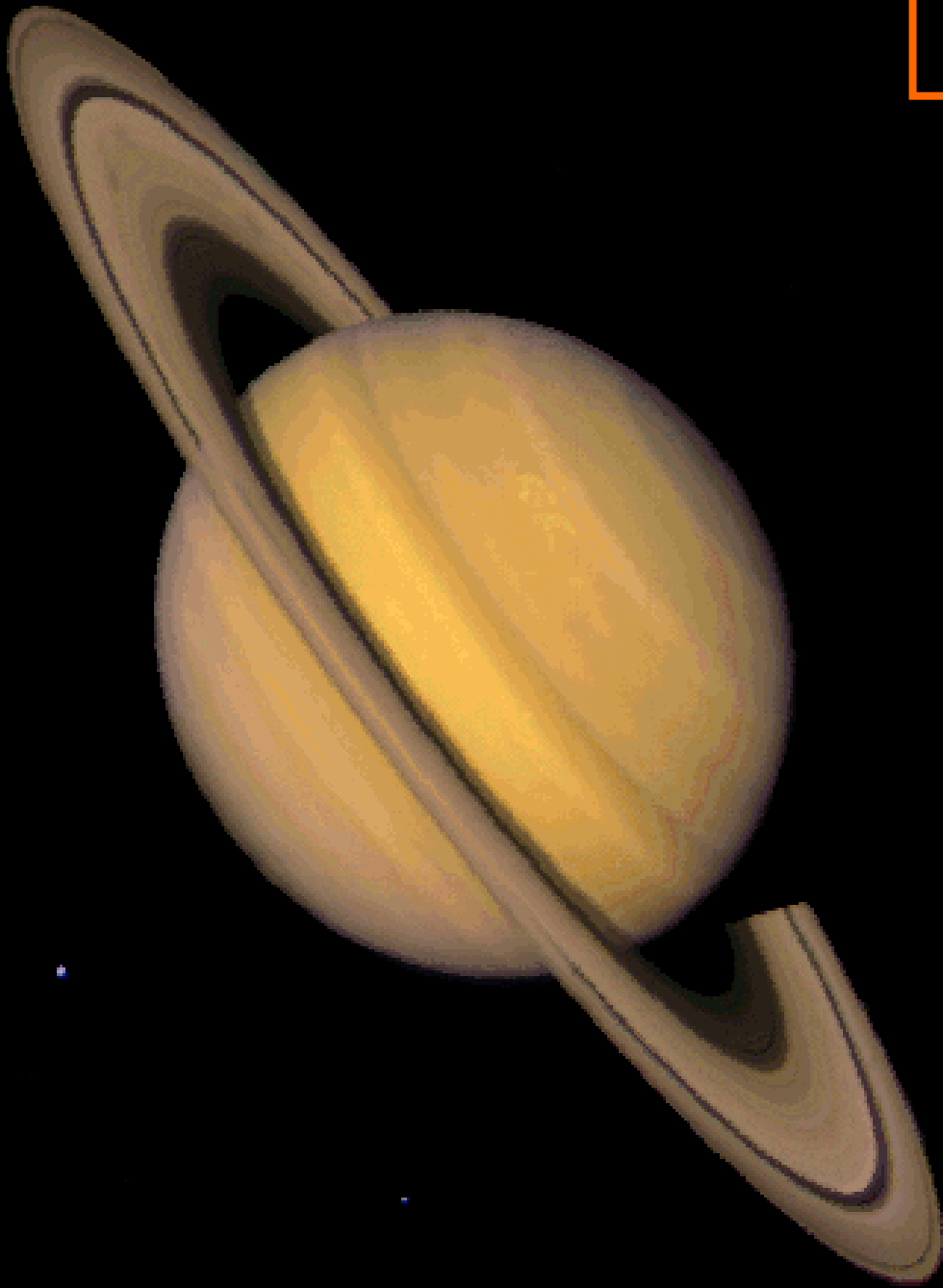

Chimenea LOCAL

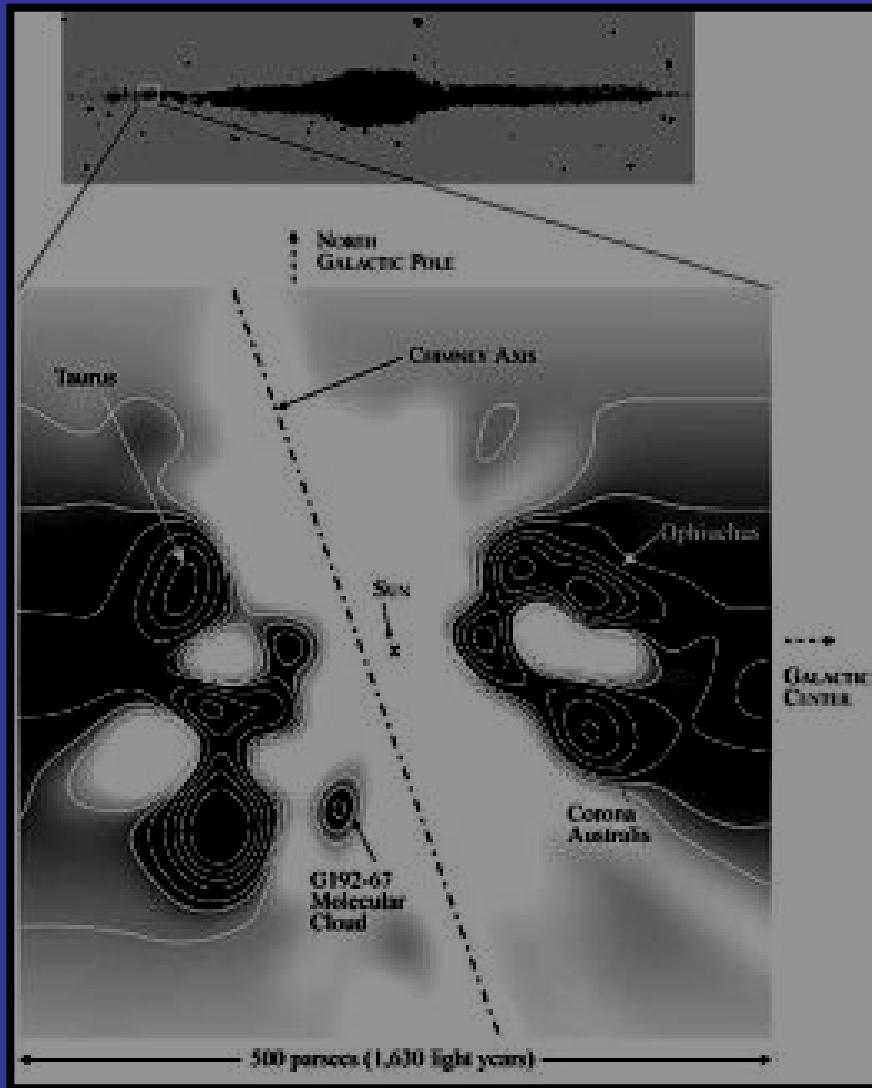

Burbuja LOCAL/Solar

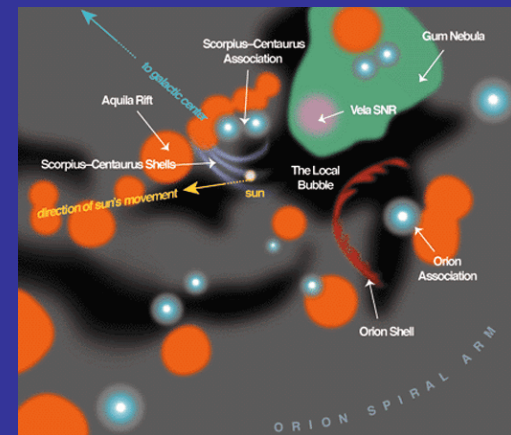
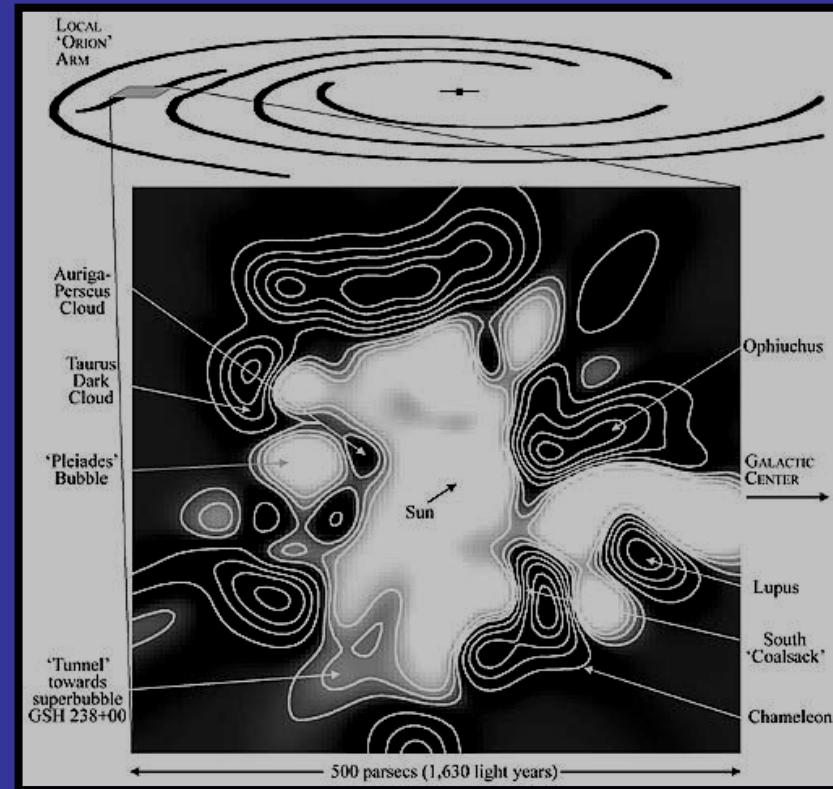

El Universo EXPLOSIVO/ACTIVO
(y el Cosmos/Kosmos)

(III) Explosiones ESTELARES

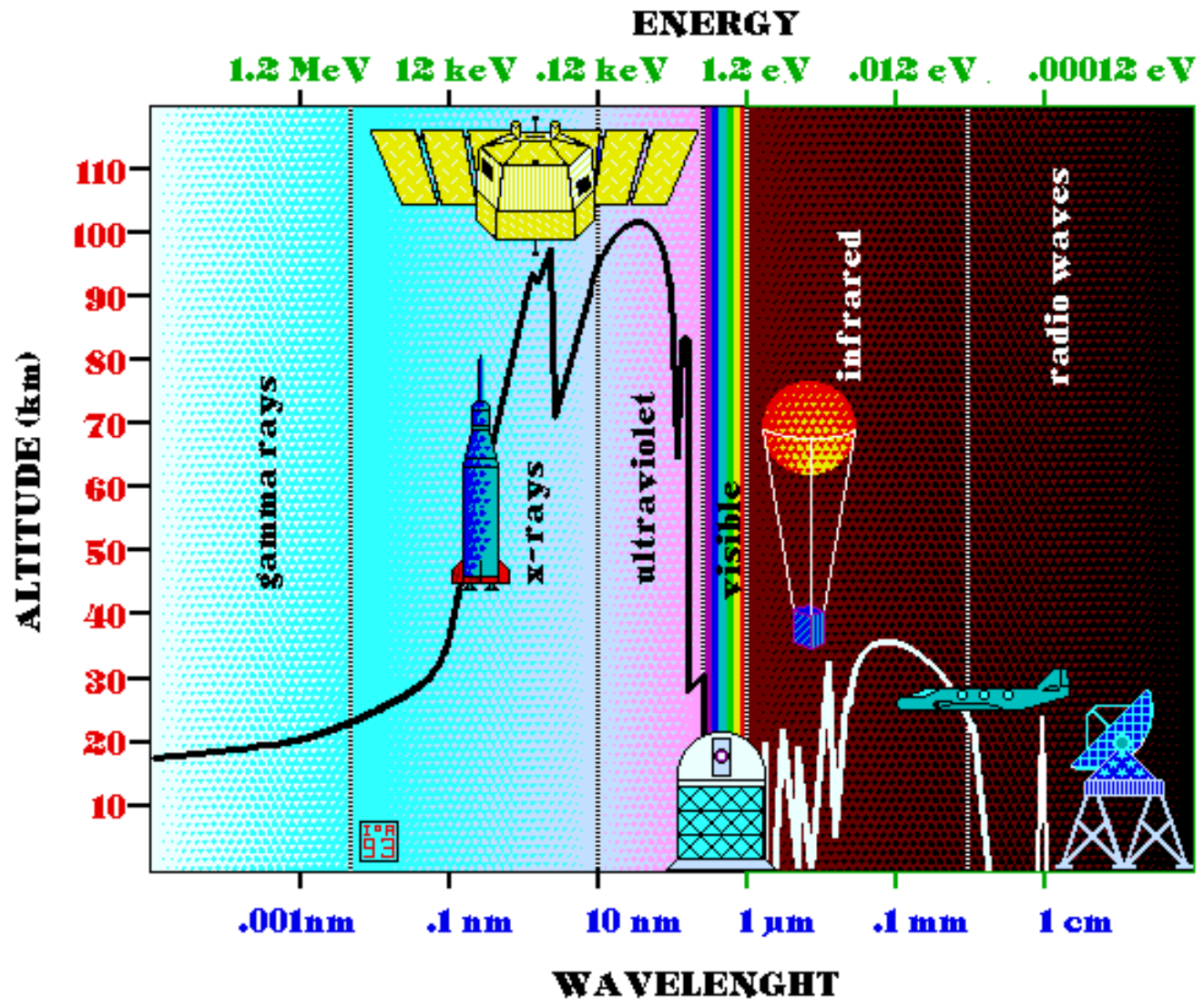

Stellar Evolution Cycles

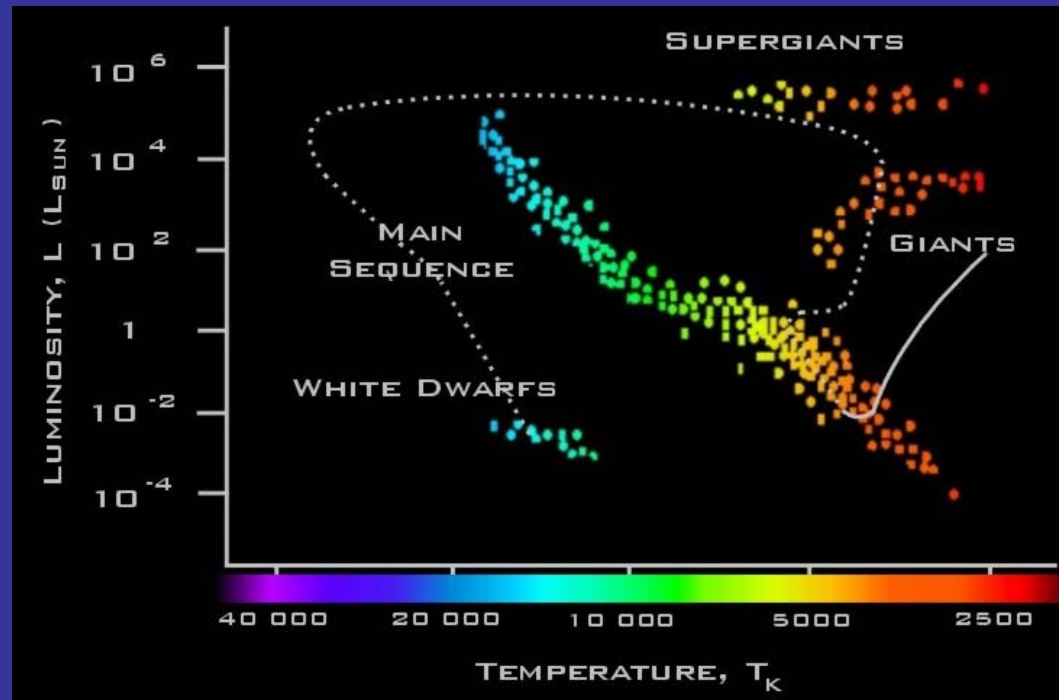
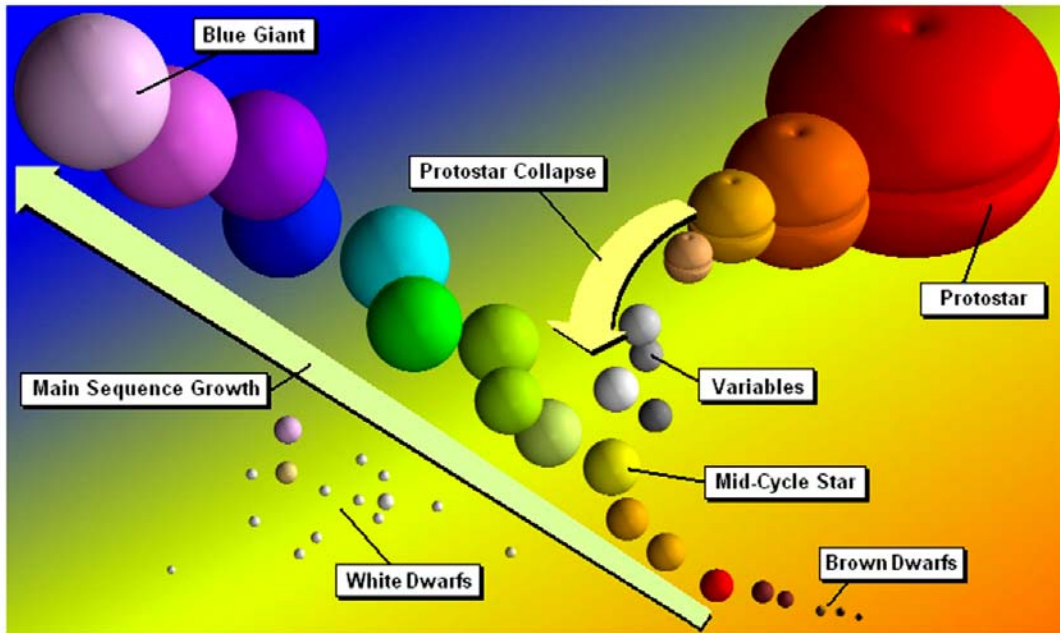

Life of a Star

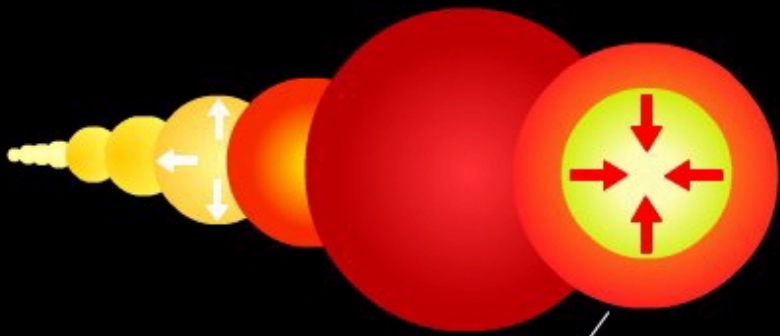

The core of the star then runs out of fuel, and collapses completely, because it is no longer producing enough energy to balance the shrinking force of gravity. Now, nuclear reactions are not able to occur in the star's core.

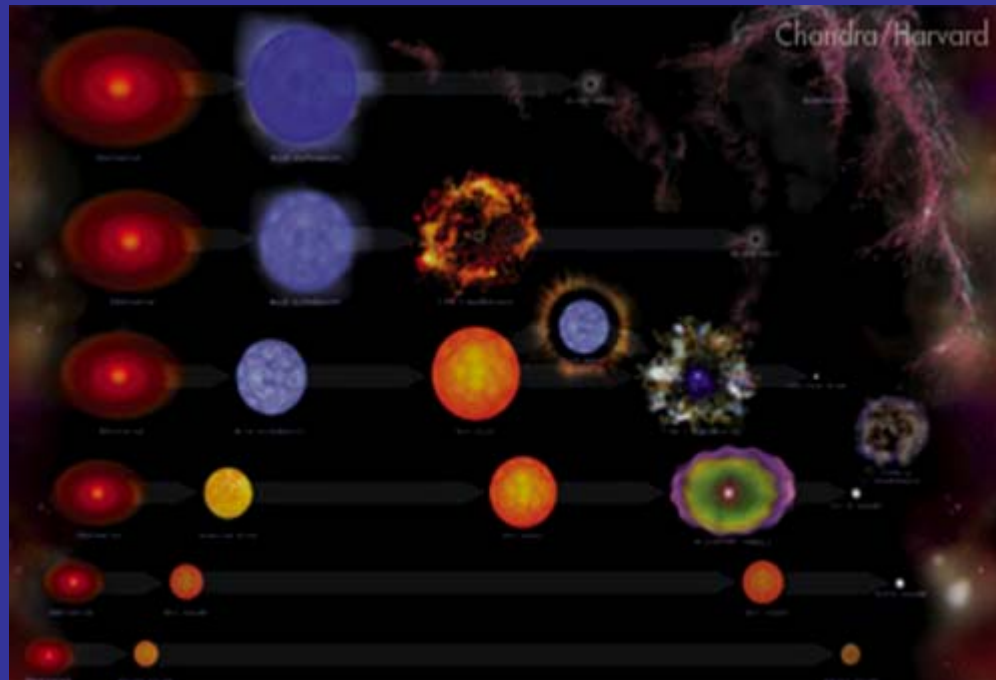

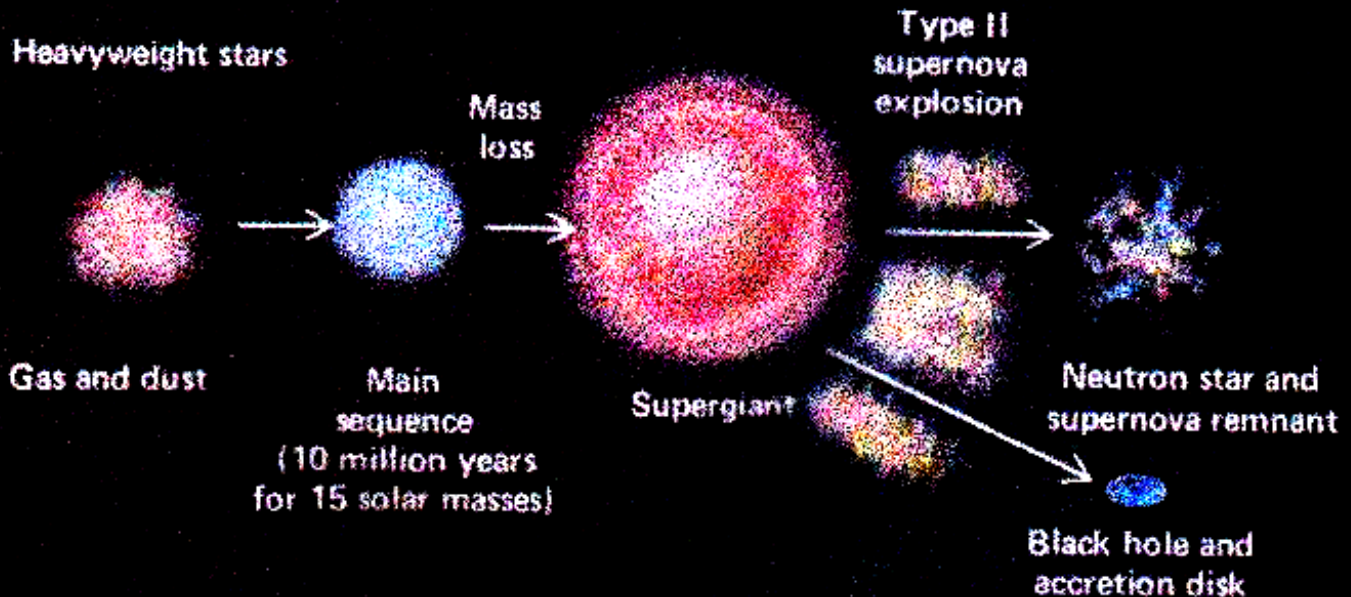
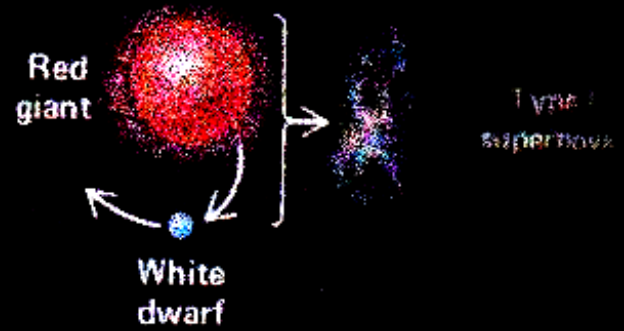
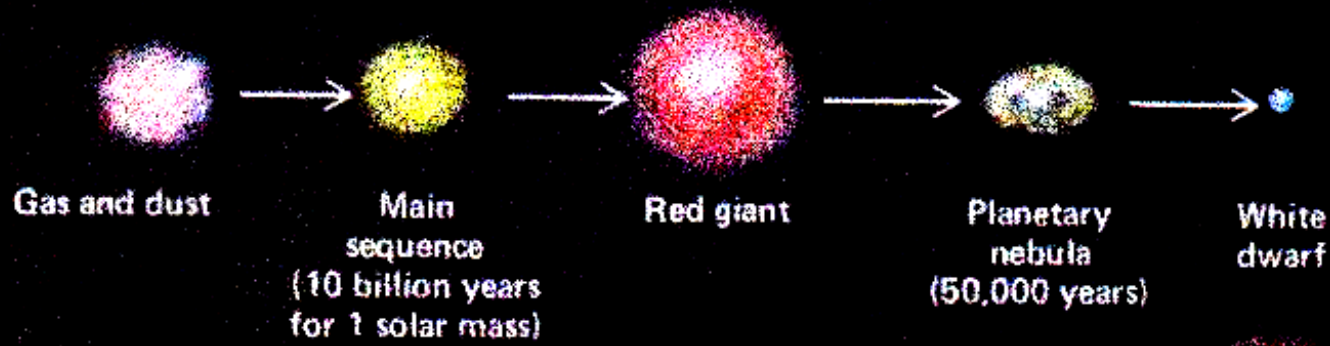

Curvas de Luz de Supe Novas

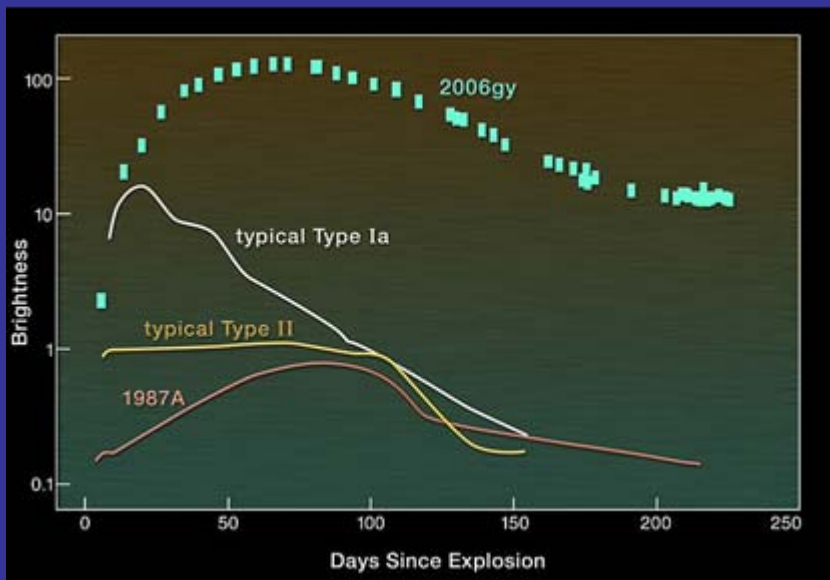
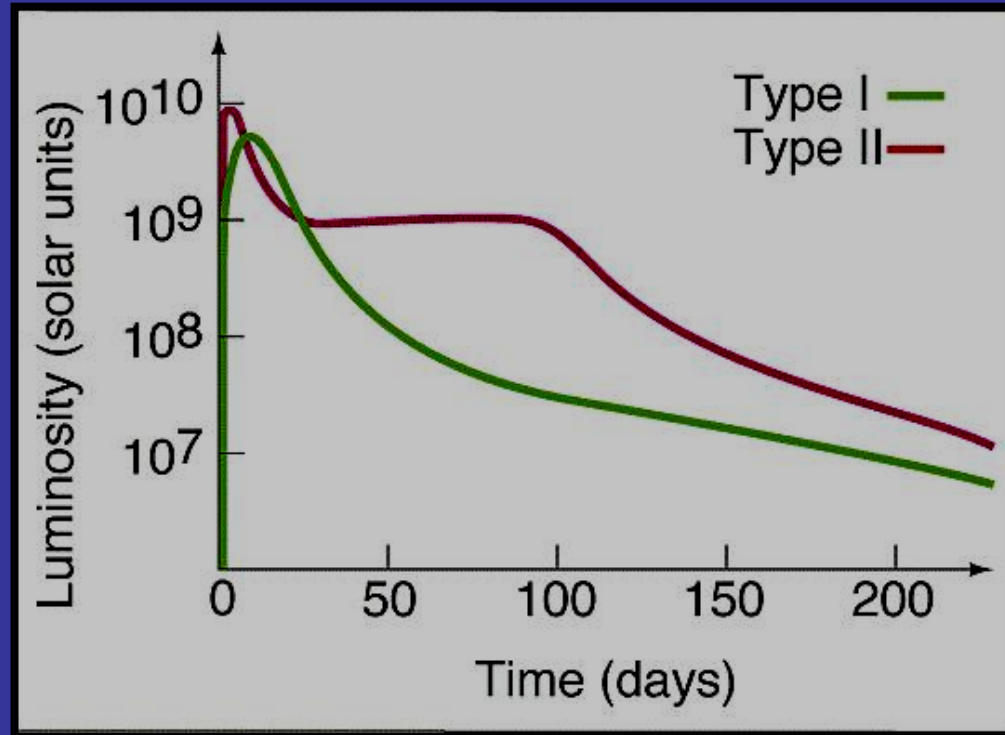

Espectros de Super Novas

SN tipo II (emision + Abs. de H) – SN1987A

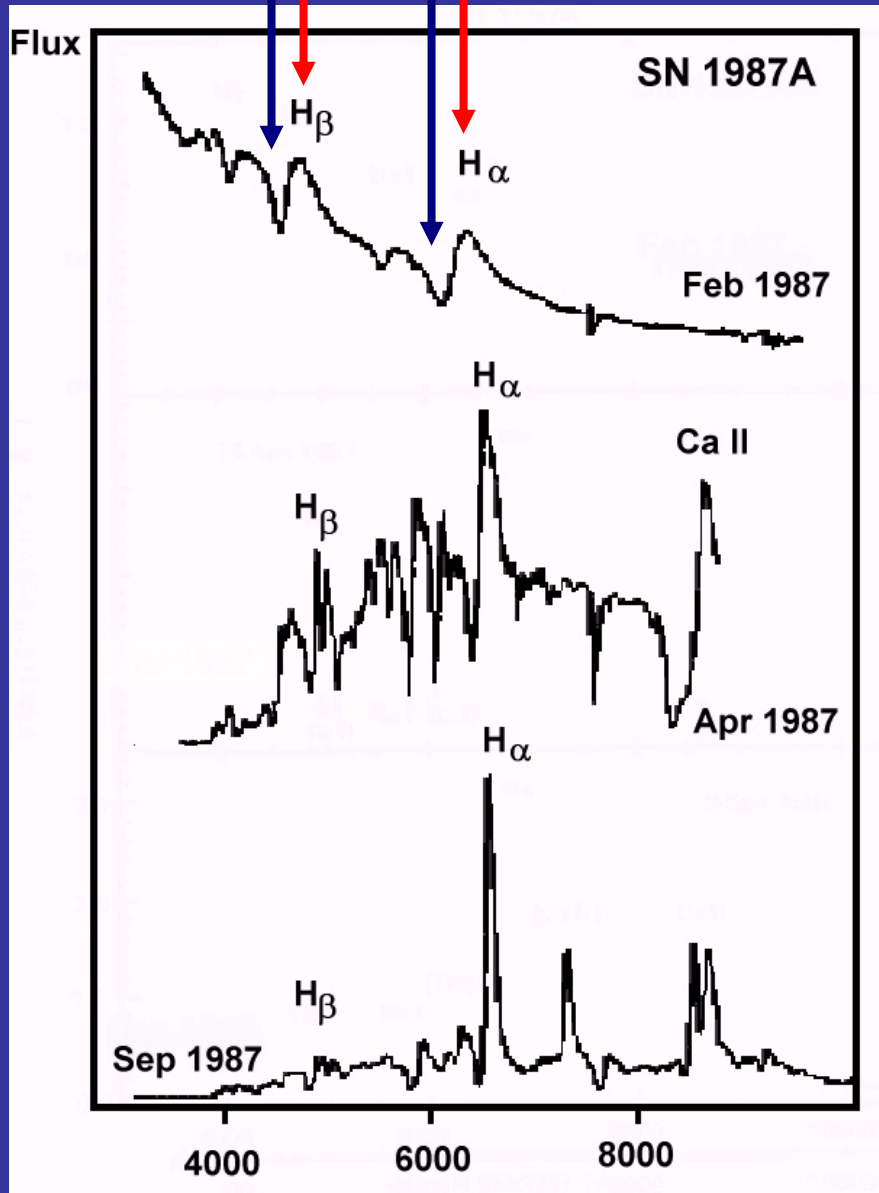

Ciclo de vida de una estrella masiva

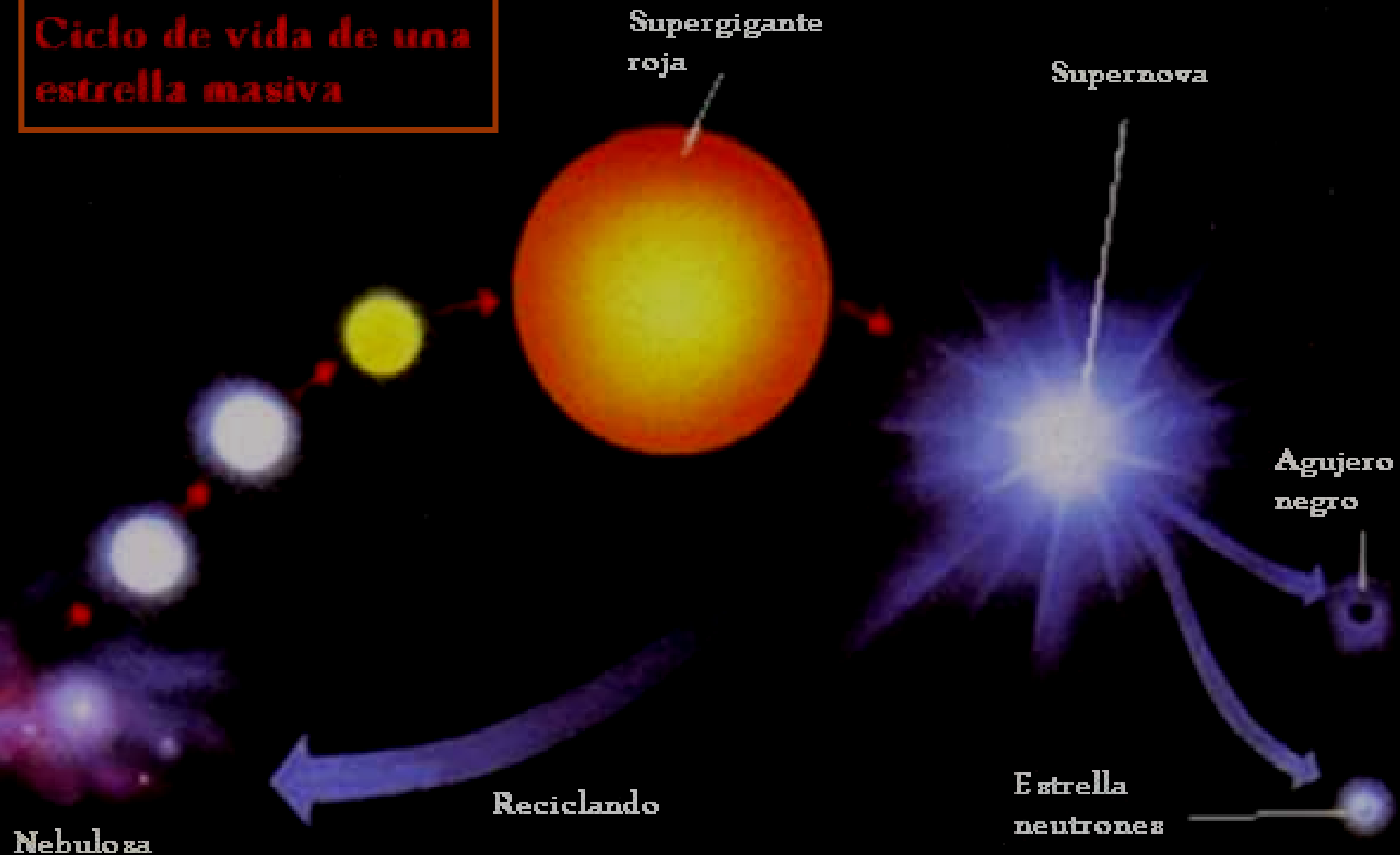



Nebulosa Eta Carinae (reg. de formacion estelar)

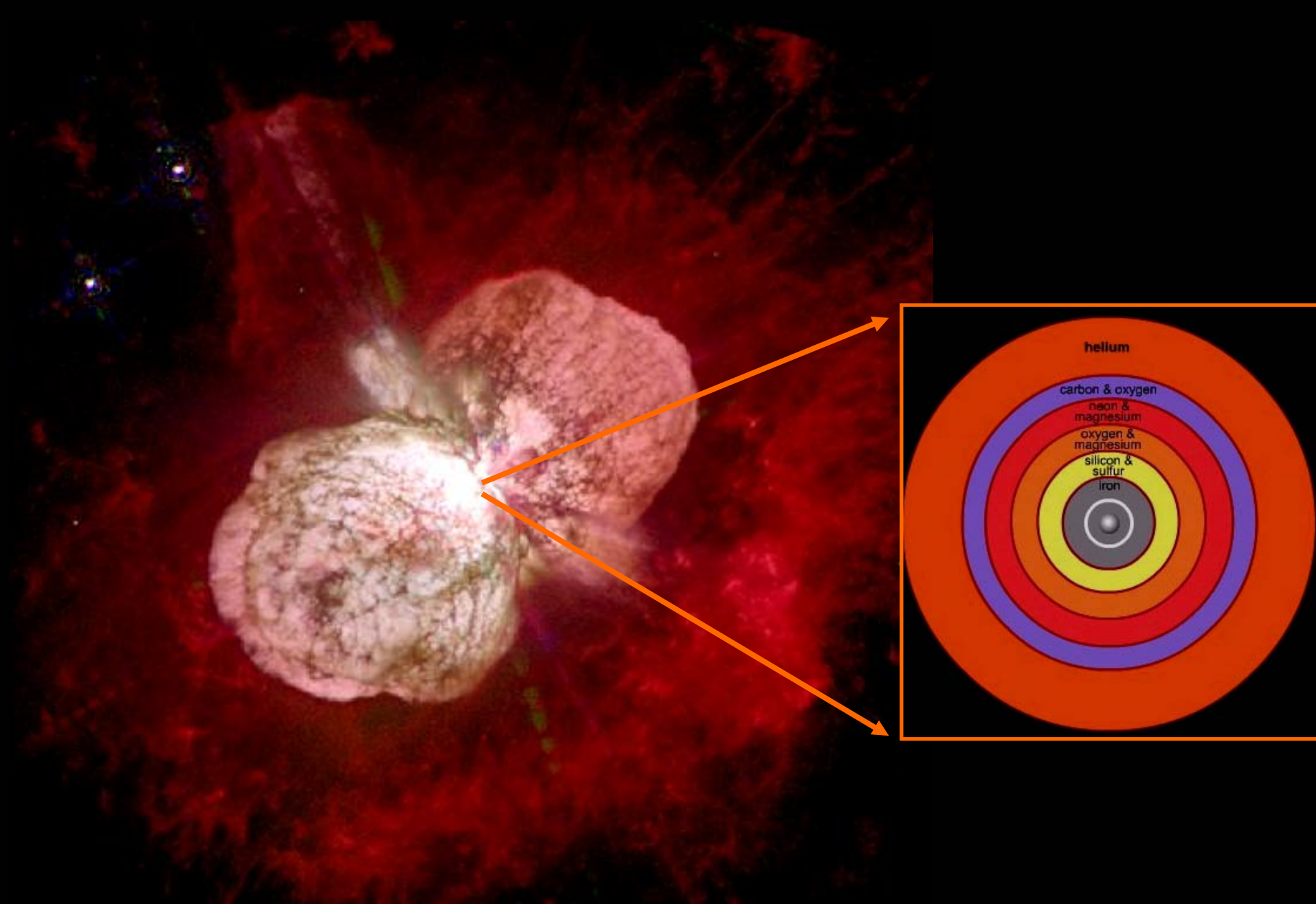

Estrella MASIVA: Eta Carinae (explosiones previas de SN II)

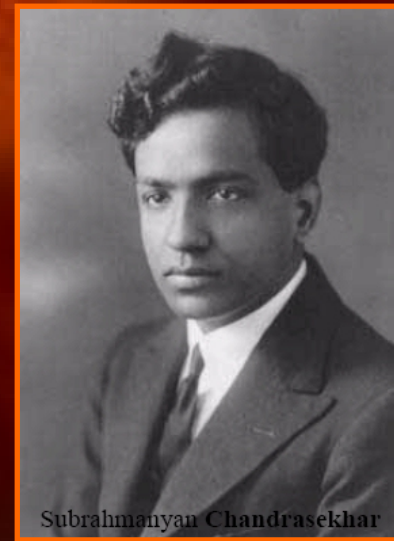

Subrahmanyan Chandrasekhar

SN Tipo Ia: Estrella Binaria, explosion de enana blanca)

Nebulosas Planetarias



NGC 2392 • “Eskimo” Nebula

HST • WFPC2

Cat's Eye Nebula • NGC 6543



Hubble
Heritage

SN 1987A (LMC)

amazing neutrinos

neutrinos detected thousands of years after supernova

Neutrinos were only theoretical until supernova SN1987A. Scientists were using underground vats of purified water designed to detect the components of decomposing protons, which, if scientist's neutrino theory were correct, would also detect neutrinos. The vats were positioned underground because neutrinos have little or no mass, and are the only things known that are known or theorized that can pass through objects, like the Earth, as if it wasn't there! This way, if the vats received anything, it had to be neutrinos.

On February 23, 1987, at 7:35:35 universal time (2:35:35 p.m. eastern standard time) two of the detectors began receiving signals that neutrinos had arrived - hours before there was visible evidence that the supernova had occurred! It was amazing that the neutrinos arrived simultaneously after a 170,000 year journey. The detectors also revealed that in a single second, SN1987A produced more energy than the sun will ever produce in its lifetime.

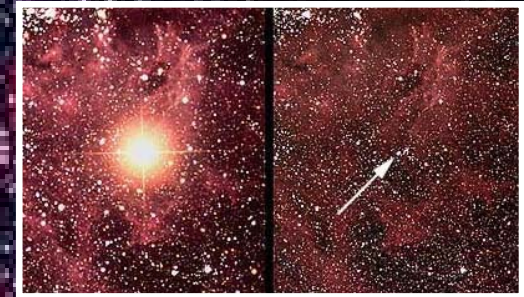

SN 1987A

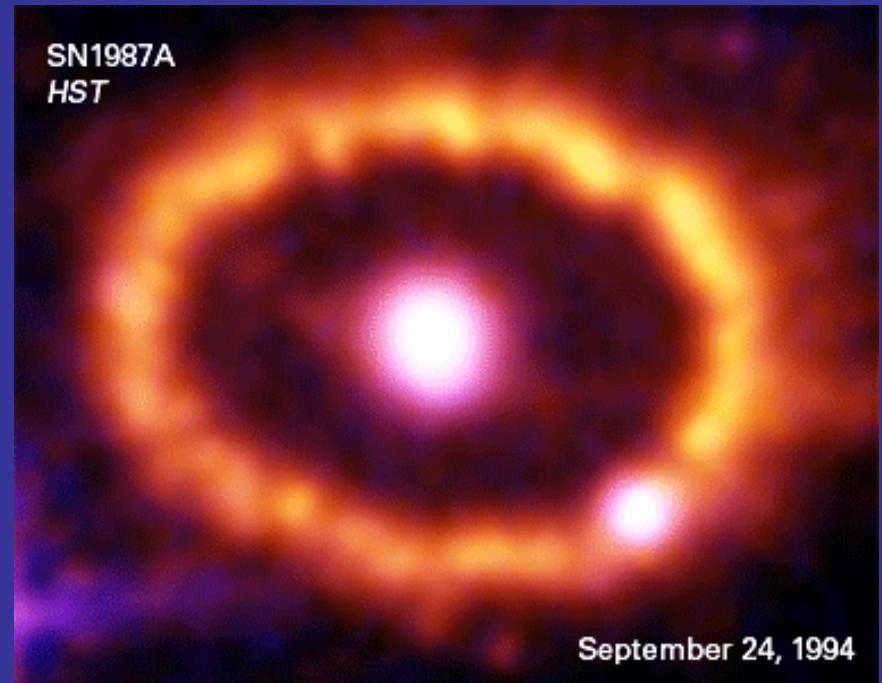
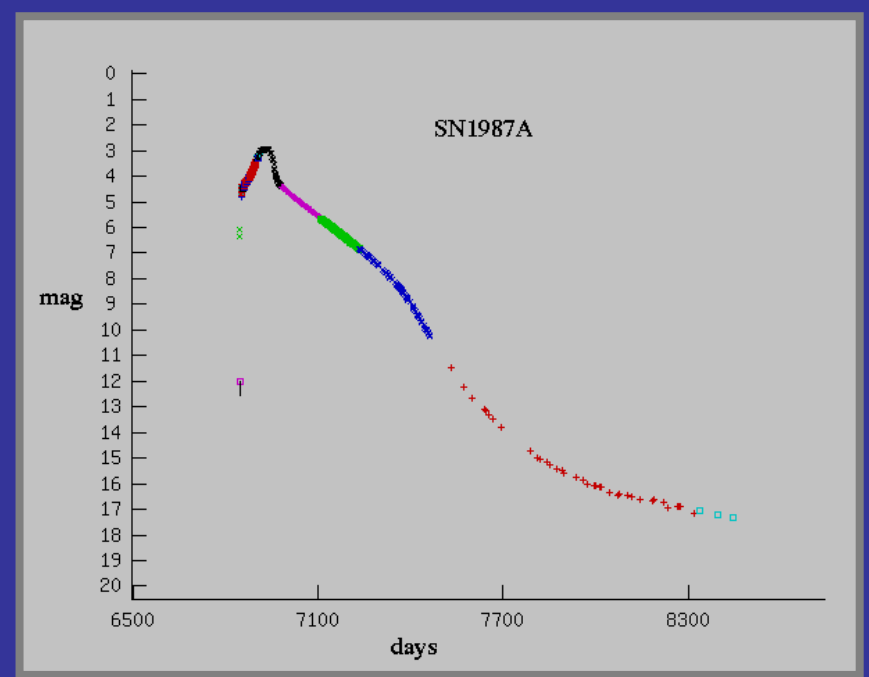
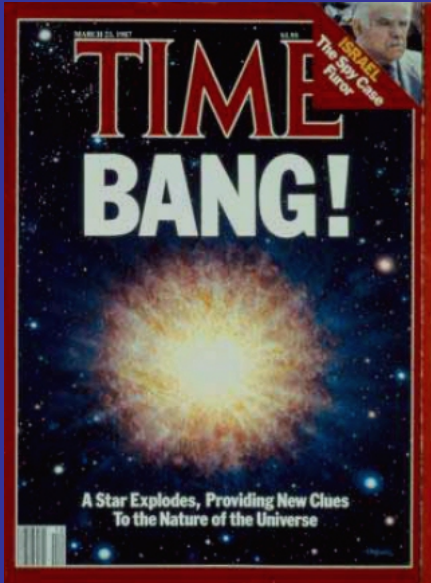

RSN Cangrejo/ Crab (en V.L.): 1054, tipo II, +Pulsar



Optico

X-Ray

RSN W50 (en V.L.): Est. Neutron/BH SS433,
Dubner et al. (1997)

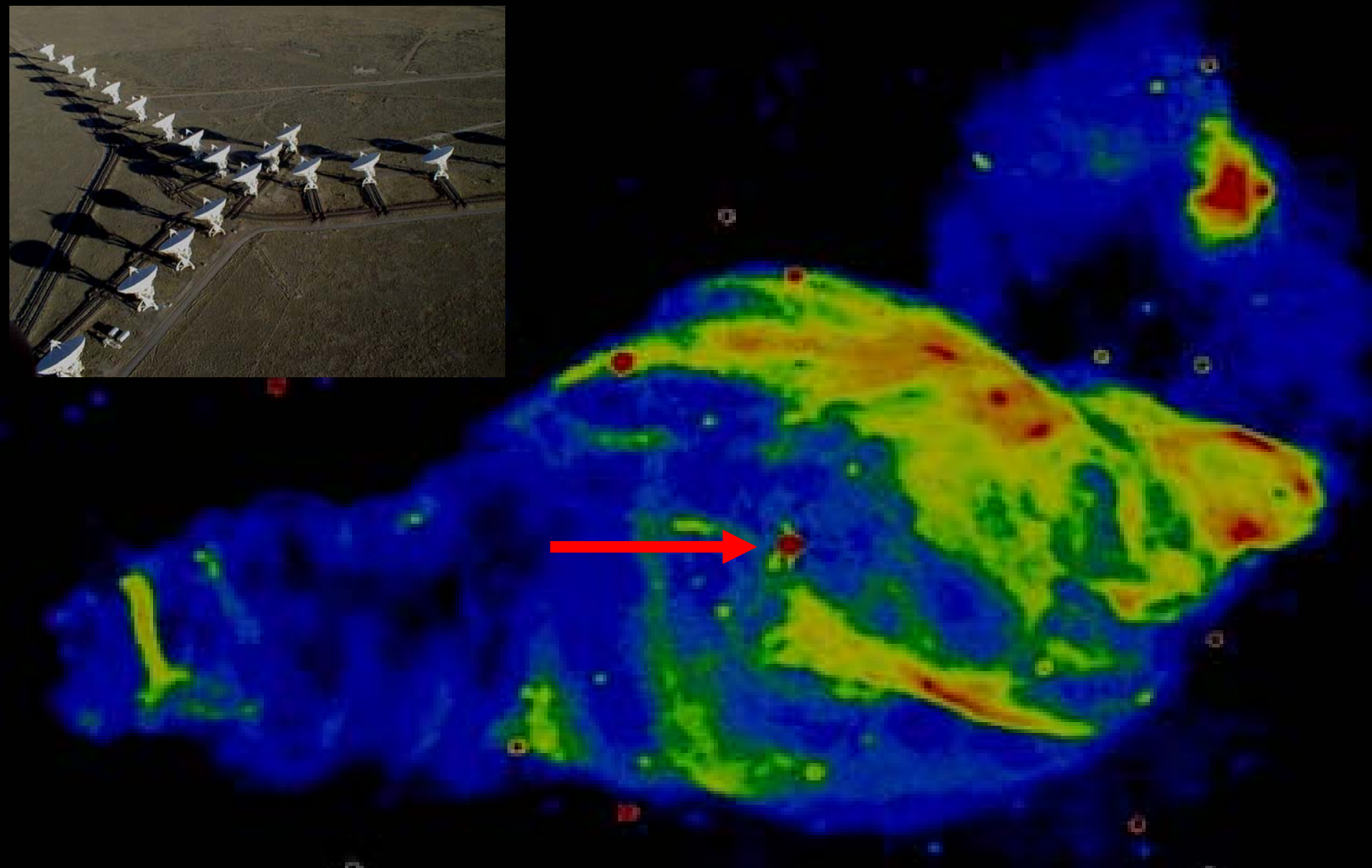

RSN Ticho (en Via Lactea): 1572, SN tipo I

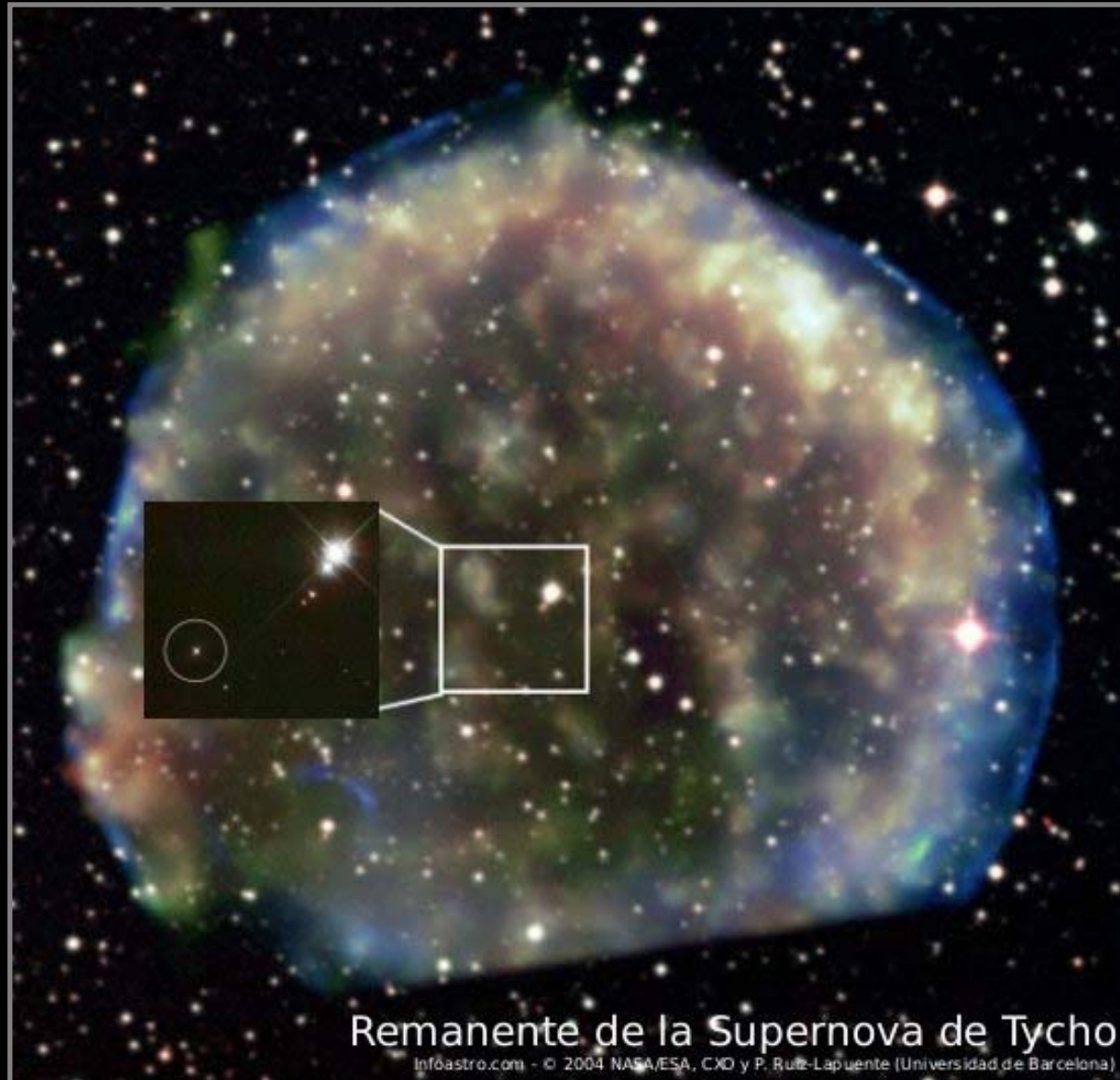

RSN Kepler (en V.L.): 1604, SN tipo I

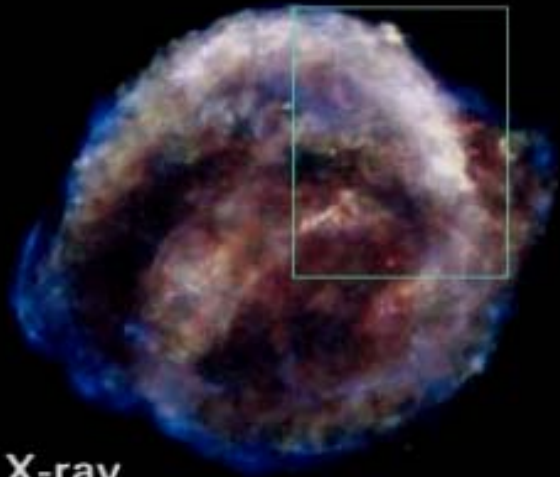

X-ray
Chandra X-ray Observatory



Visible
Hubble Space Telescope

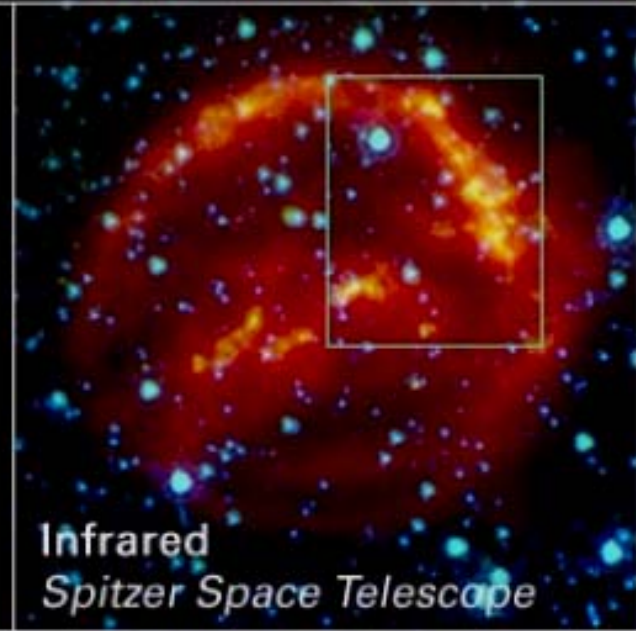

Infrared
Spitzer Space Telescope

RSN Casiopea A (en V.L.): 1680, SN tipo II

Cassiopeia A
HST • WFPC2
R. Fesen (Dartmouth)
J. Morse (U.CO)

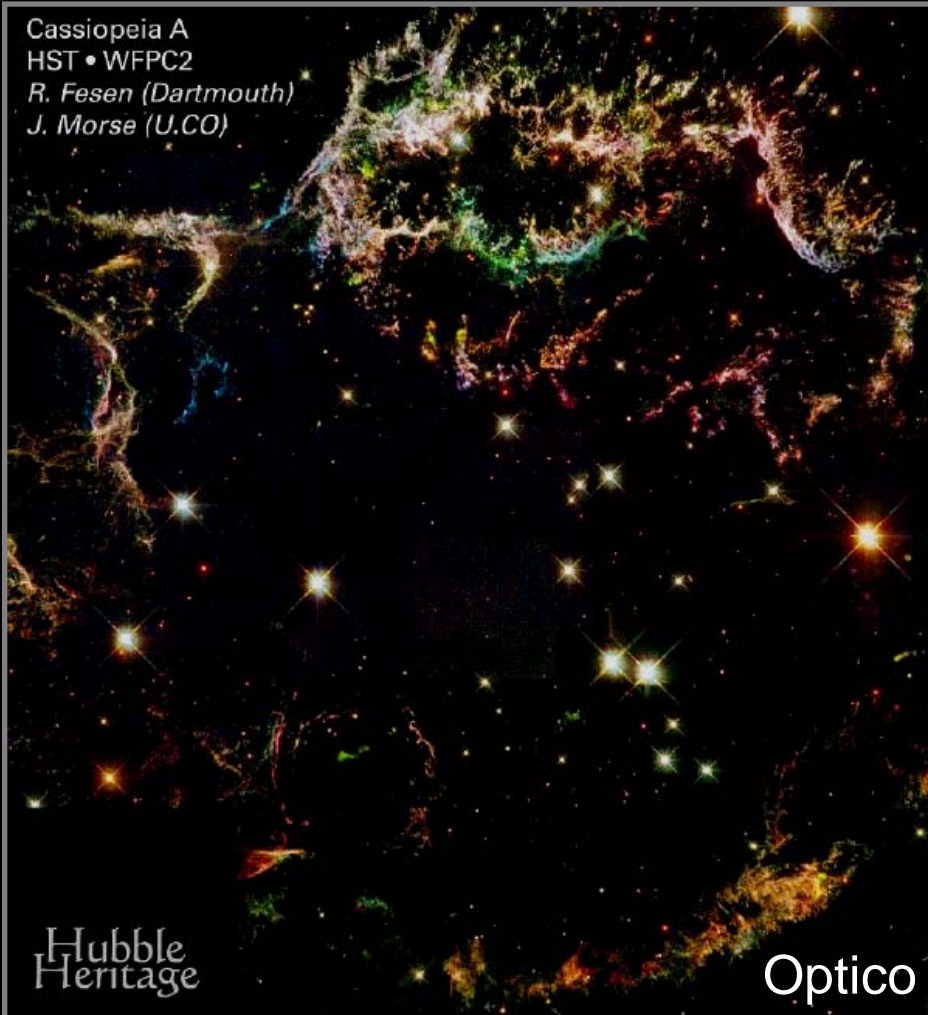

Hubble
Heritage

Optico



X-Ray

SN en Centauro A

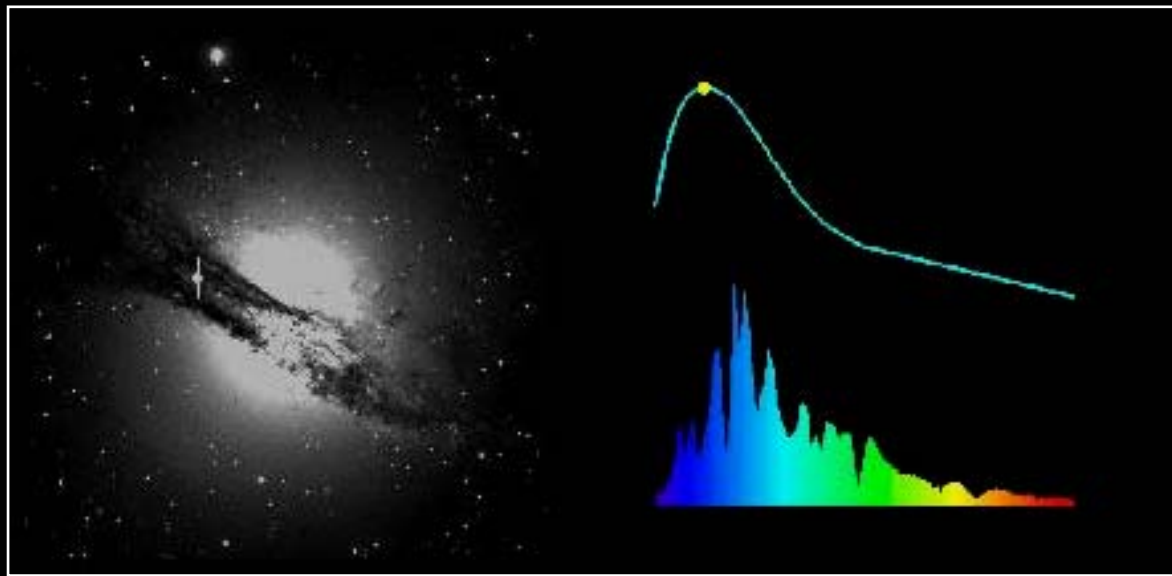

Gamma Ray Telescop. 1990

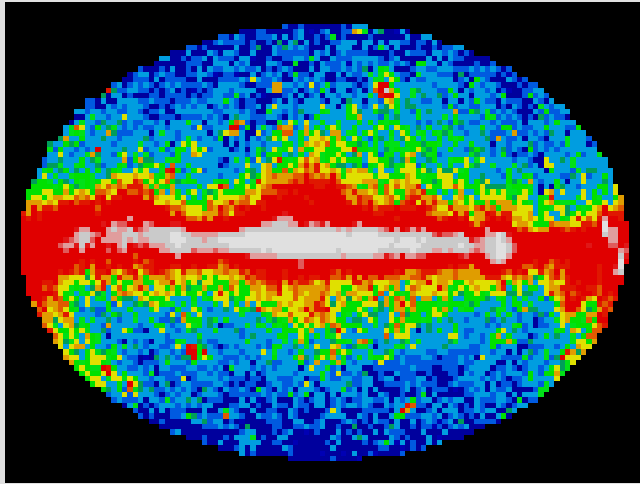

Counts per Second

30000

20000

10000

0

Time in Seconds

Gamma Ray Burst

GRB

Gamma-Ray Burst Host Galaxies

Hubble Space Telescope

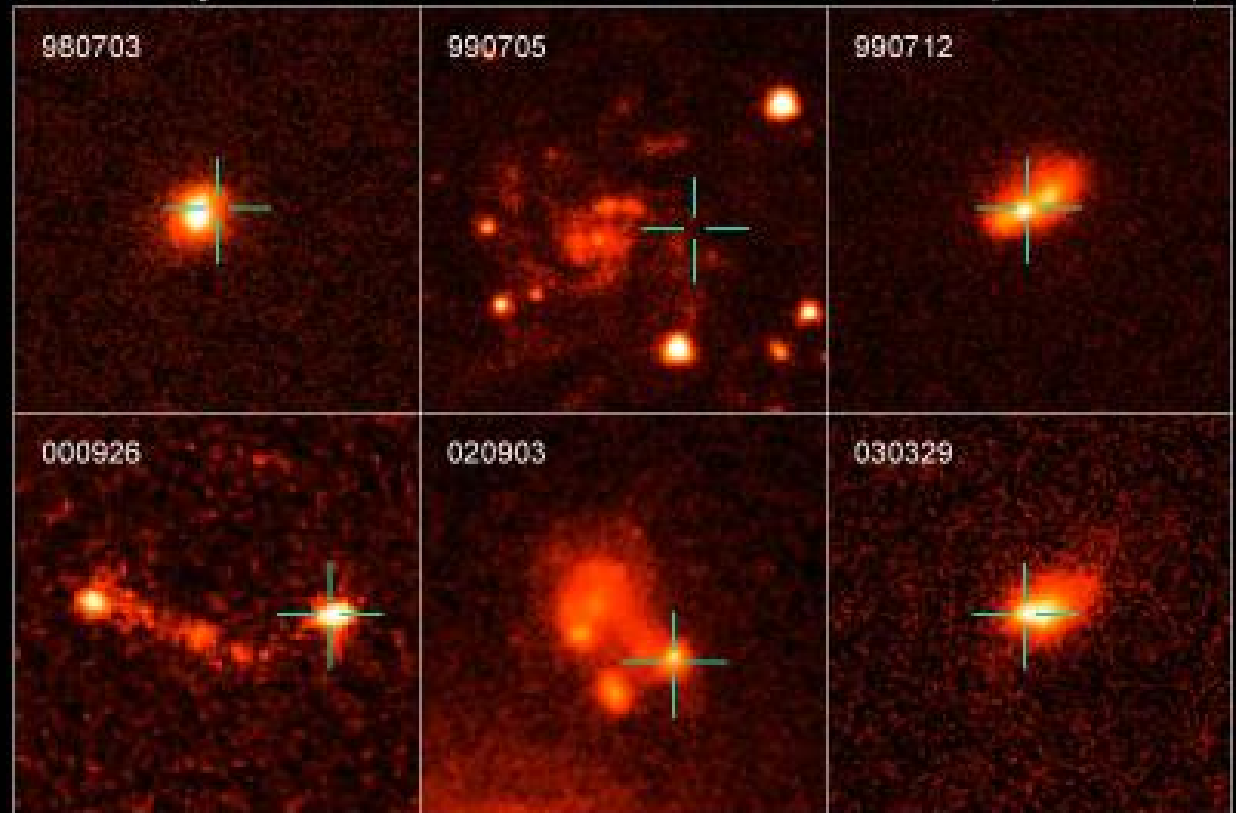

NASA, ESA, A. Fruchter (STScI), and the G0SH Collaboration

STScI-PRC06-20

Hiper Novas

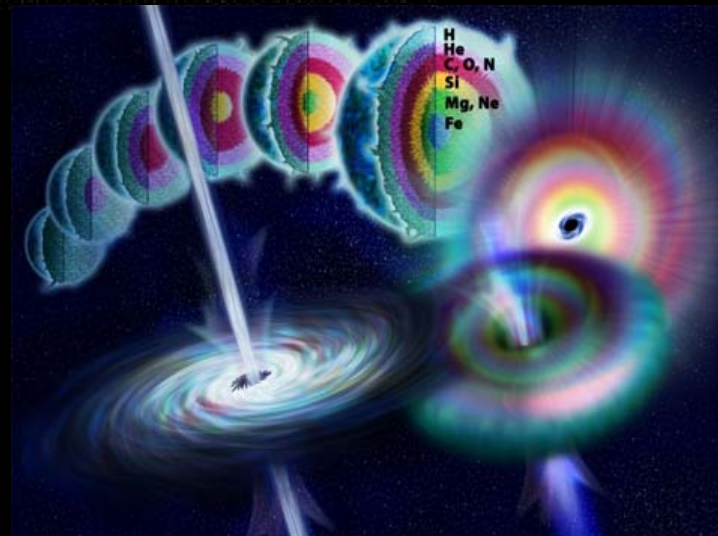

GRB

Gamma-Ray Bursts (GRBs): The Long and Short of It

Long gamma-ray burst (>2 seconds' duration)

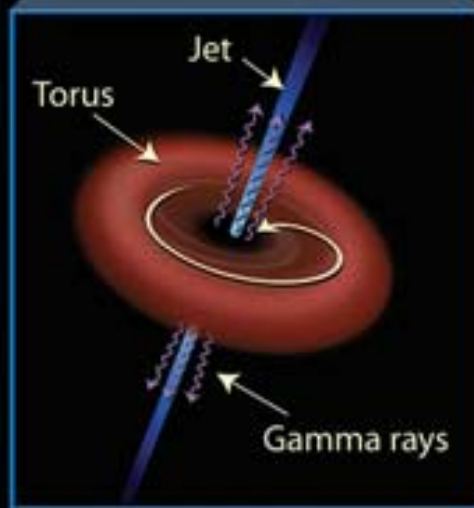

Short gamma-ray burst (<2 seconds' duration)

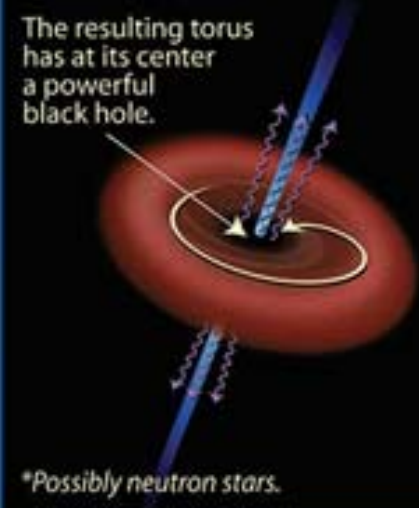

SN Tipo Ia +Cosmologia

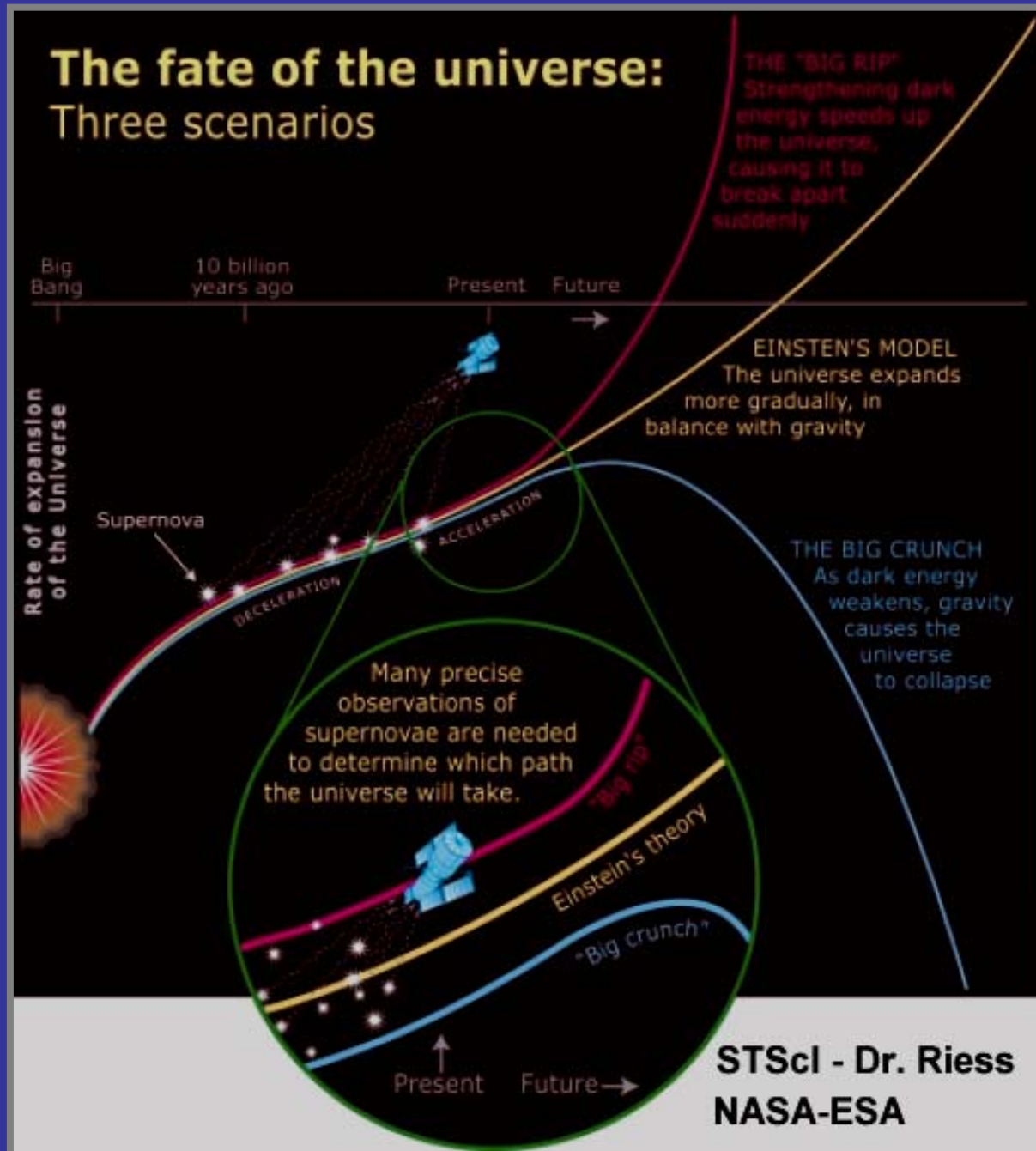

Four months in the life of a SN Ia

Age:

-6 days

Maximum

+26 days

+47 days

+102 days



On the Rise:

Powered by radioactivity

$V_{\text{ejecta}} = 10\text{-}20,000 \text{ km/s}$

Elements produced =
Fe, Co, Ni, Si, Ca

Distant Supernovae

Hubble Space Telescope • ACS

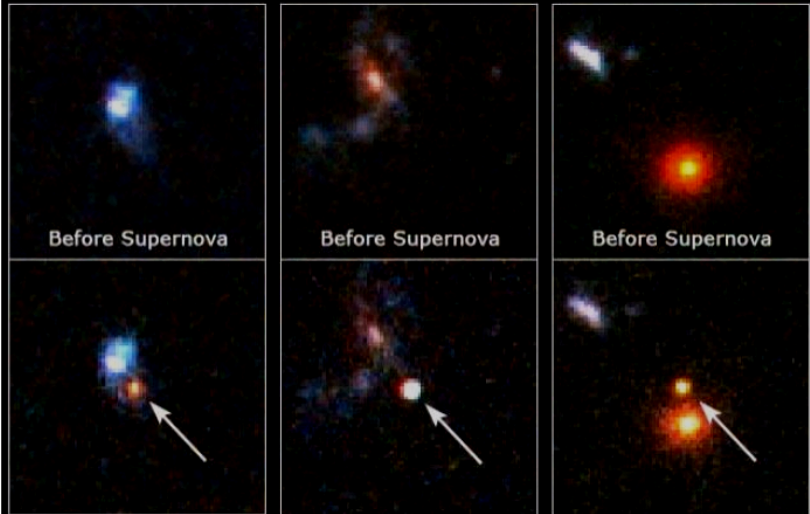

NASA and A. Riess (STScI)

STScI-PRC04-12

Epoch 1

Epoch 2

Epoch 2 - Epoch 1

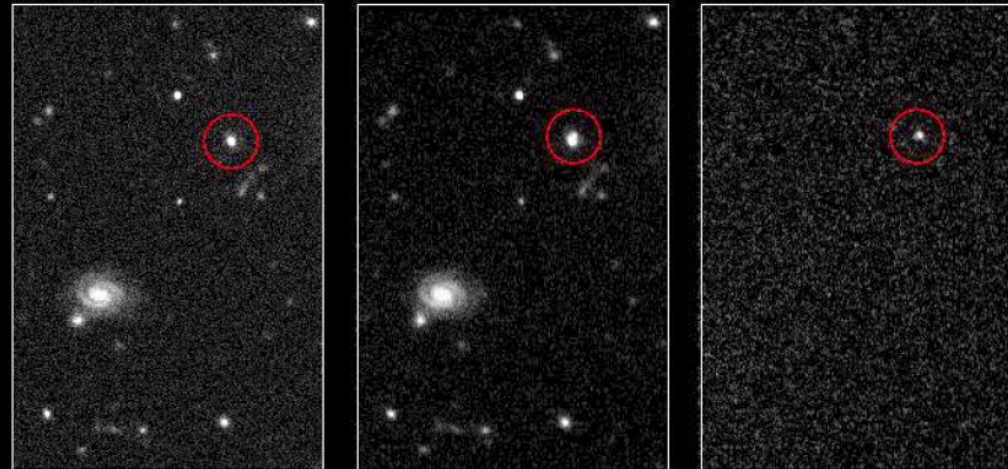

Models of the EXPANDING UNIVERSE

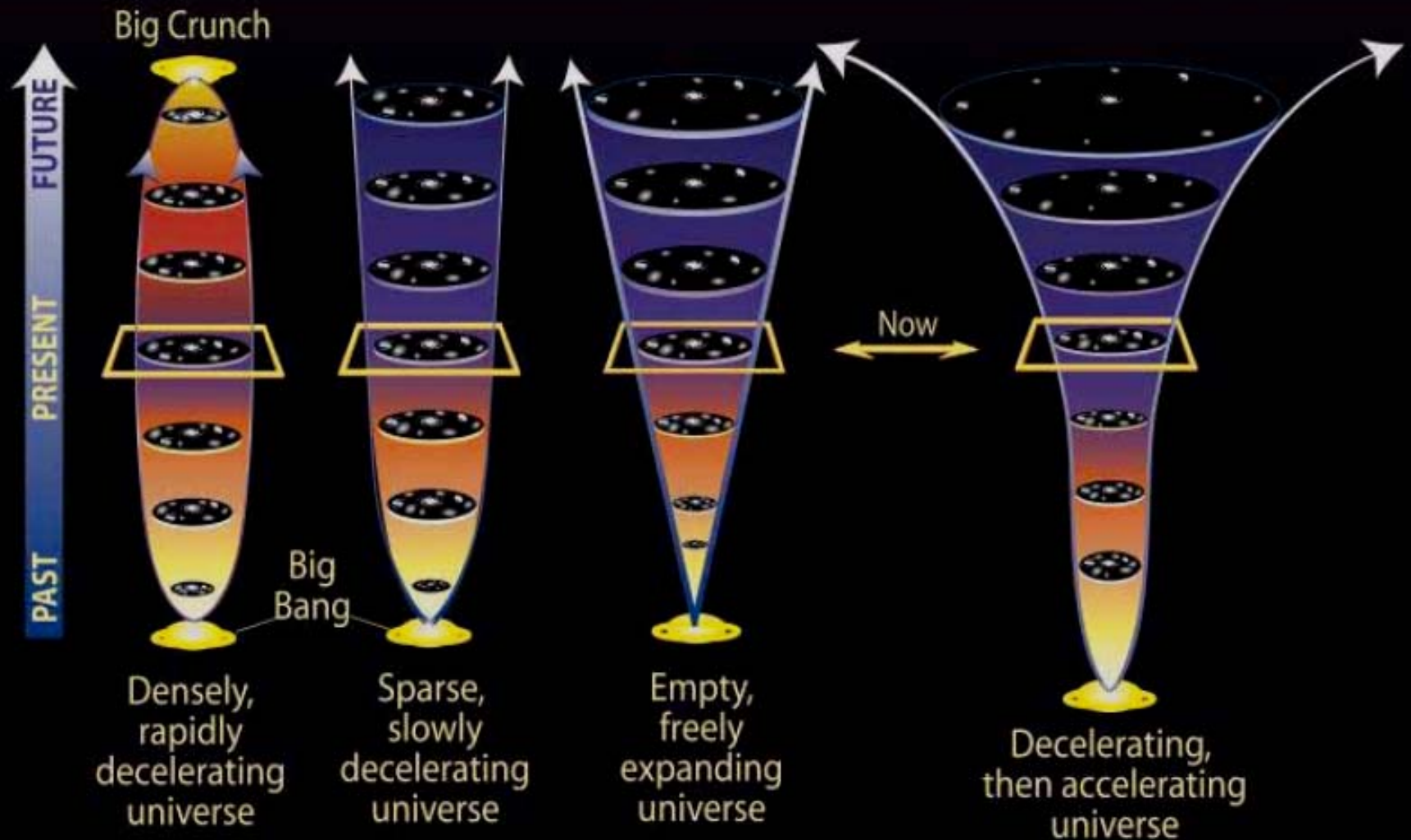

El Universo EXPLOSIVO/ACTIVO
(y el Cosmos/Kosmos)

(IV) Explosiones en STARBURST
(starburst: formacion estelar violenta)

NGC 3079 (RHII en V.L.)

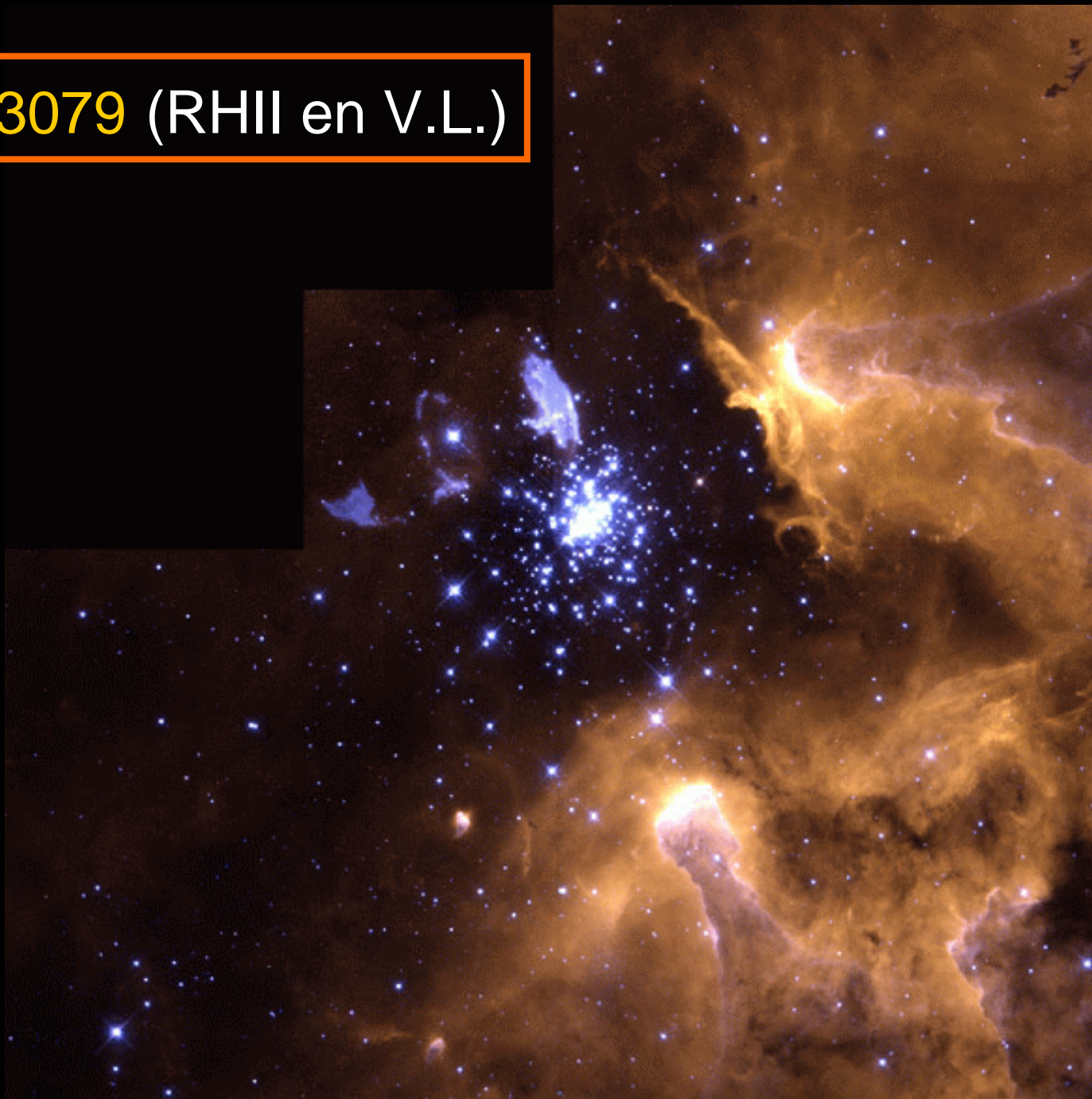

LMC 30 Dorado (Tarantula)

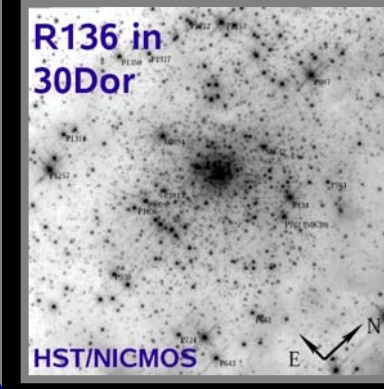
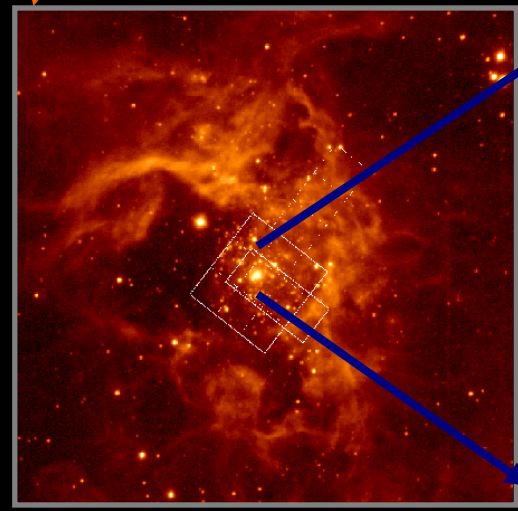
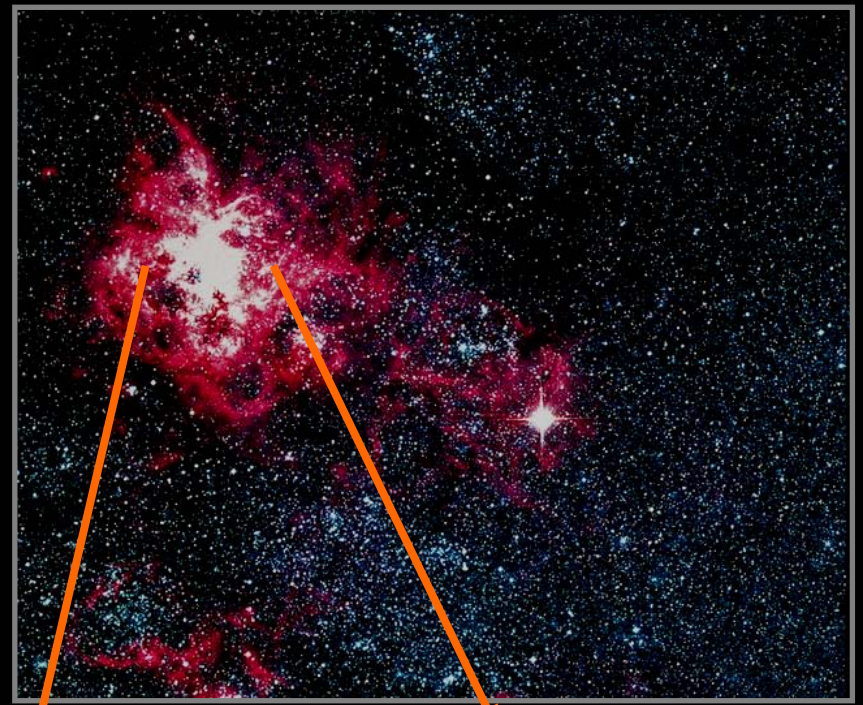
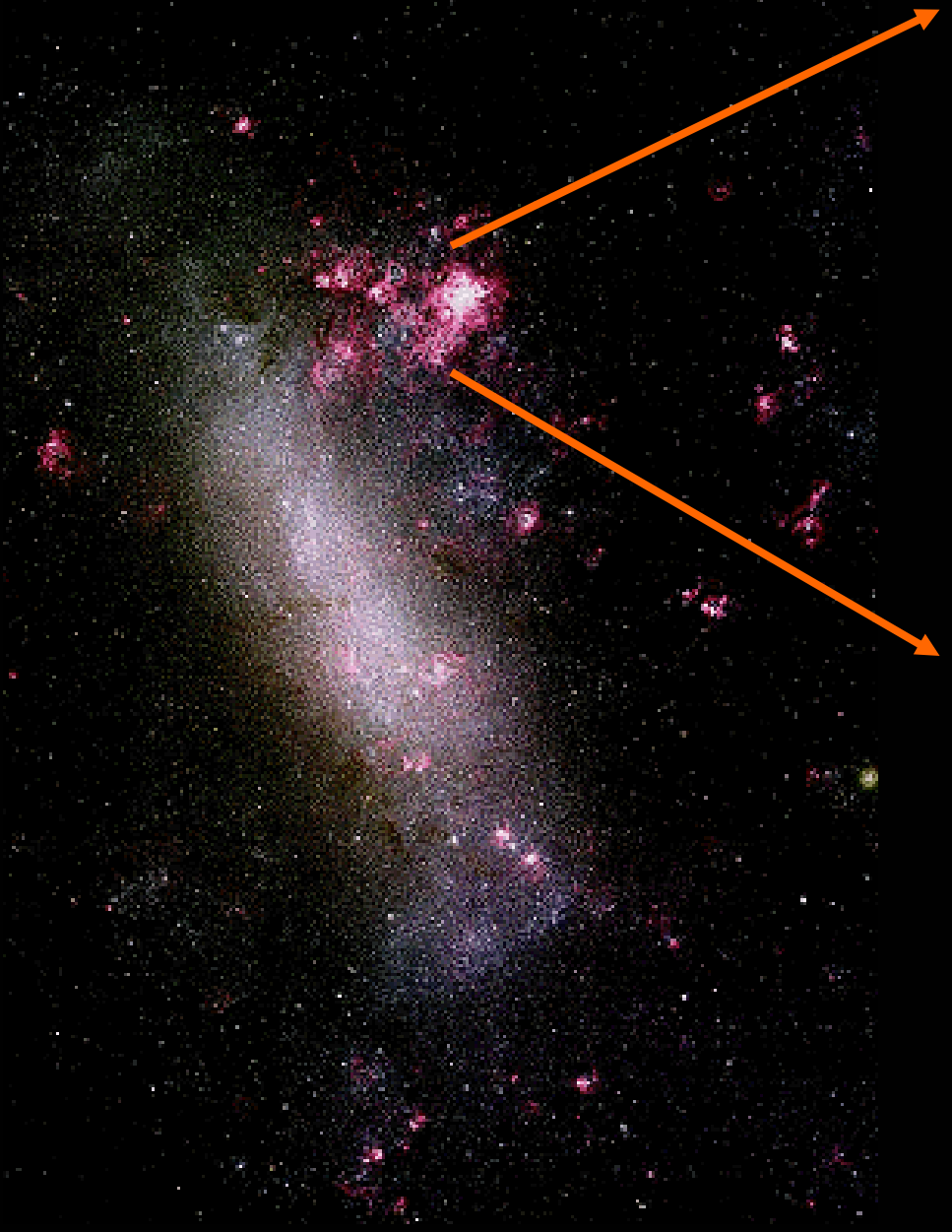

Galactic Winds (in StarBurst)

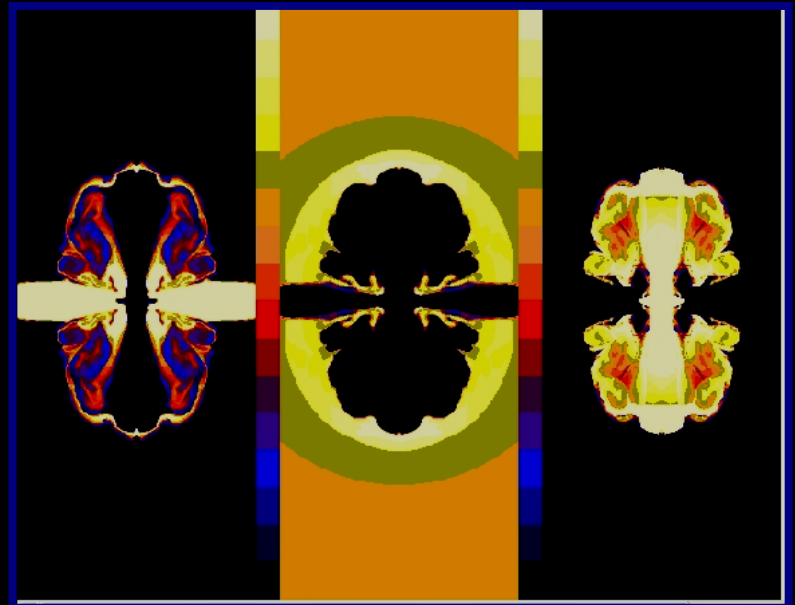
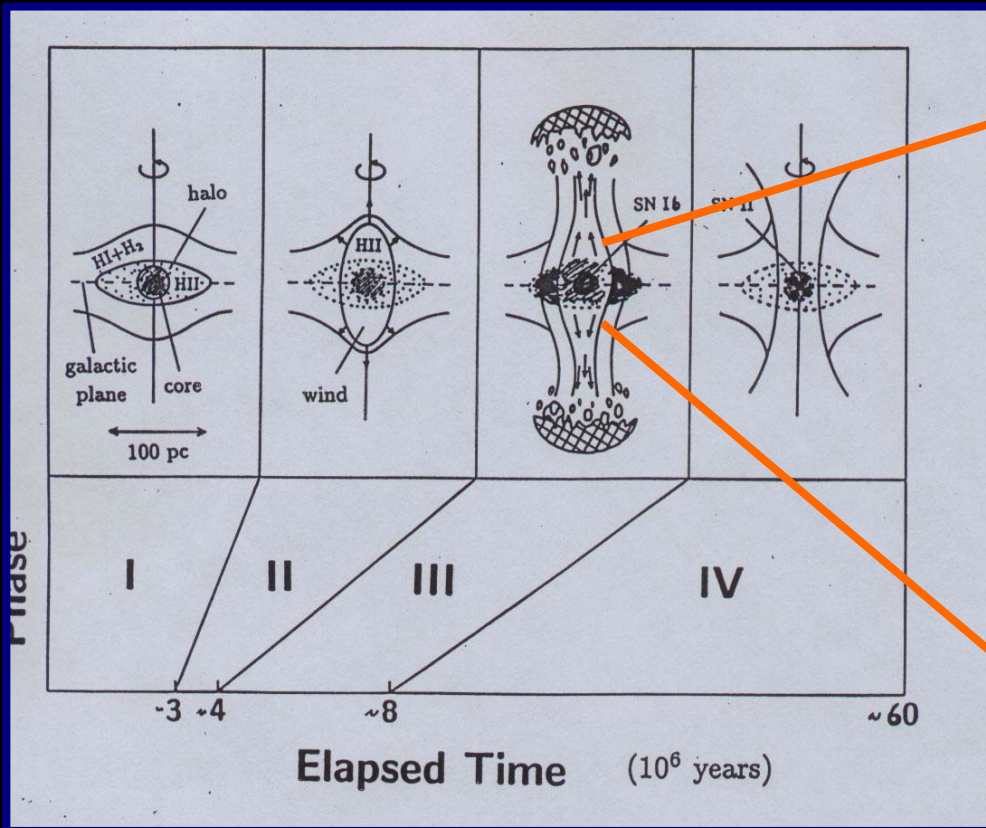
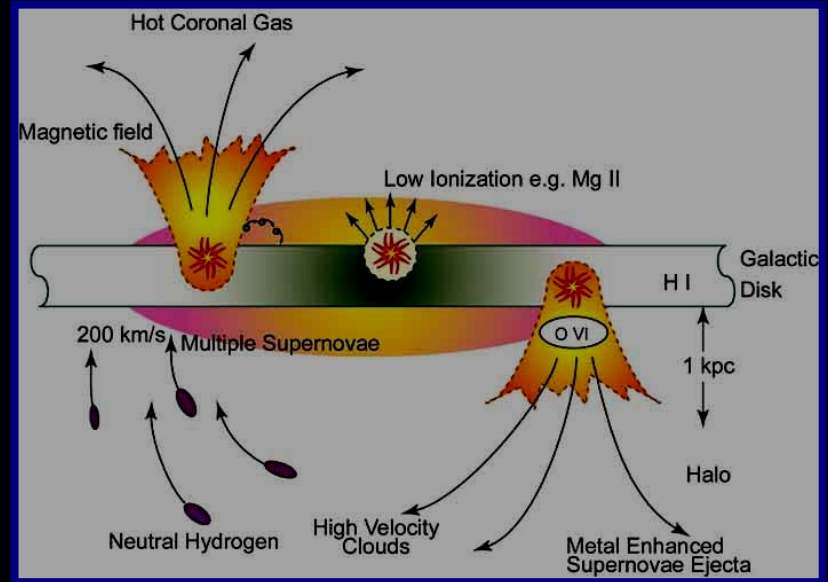

Modelo Suchkov et al. (1994, 1996)

Galactic Winds (in StarBurst)

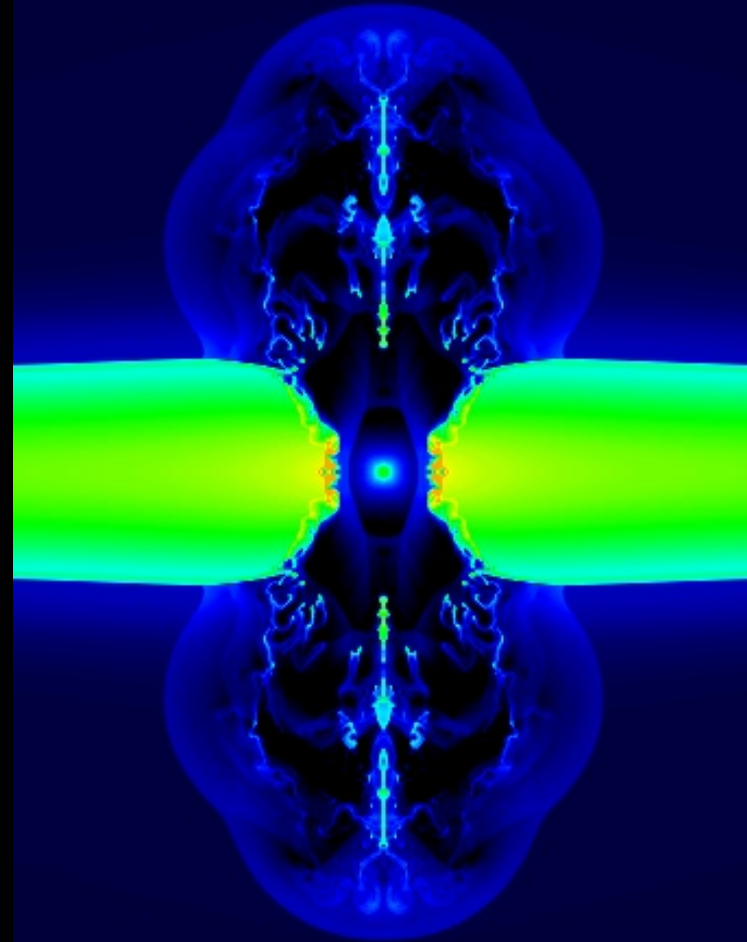
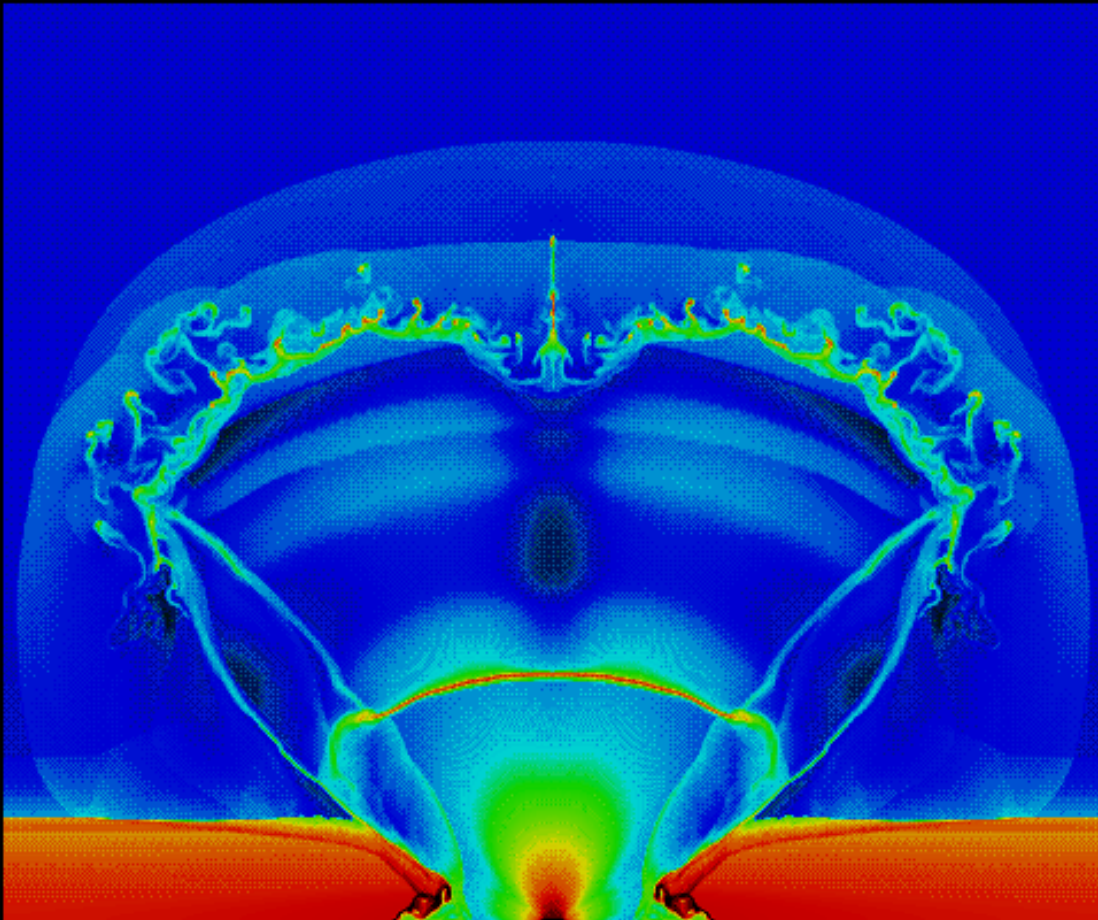

**El Universo EXPLOSIVO/ACTIVO
(y el Cosmos/Kosmos)**

(V) Explosiones en GALAXIAS

Via Lactea

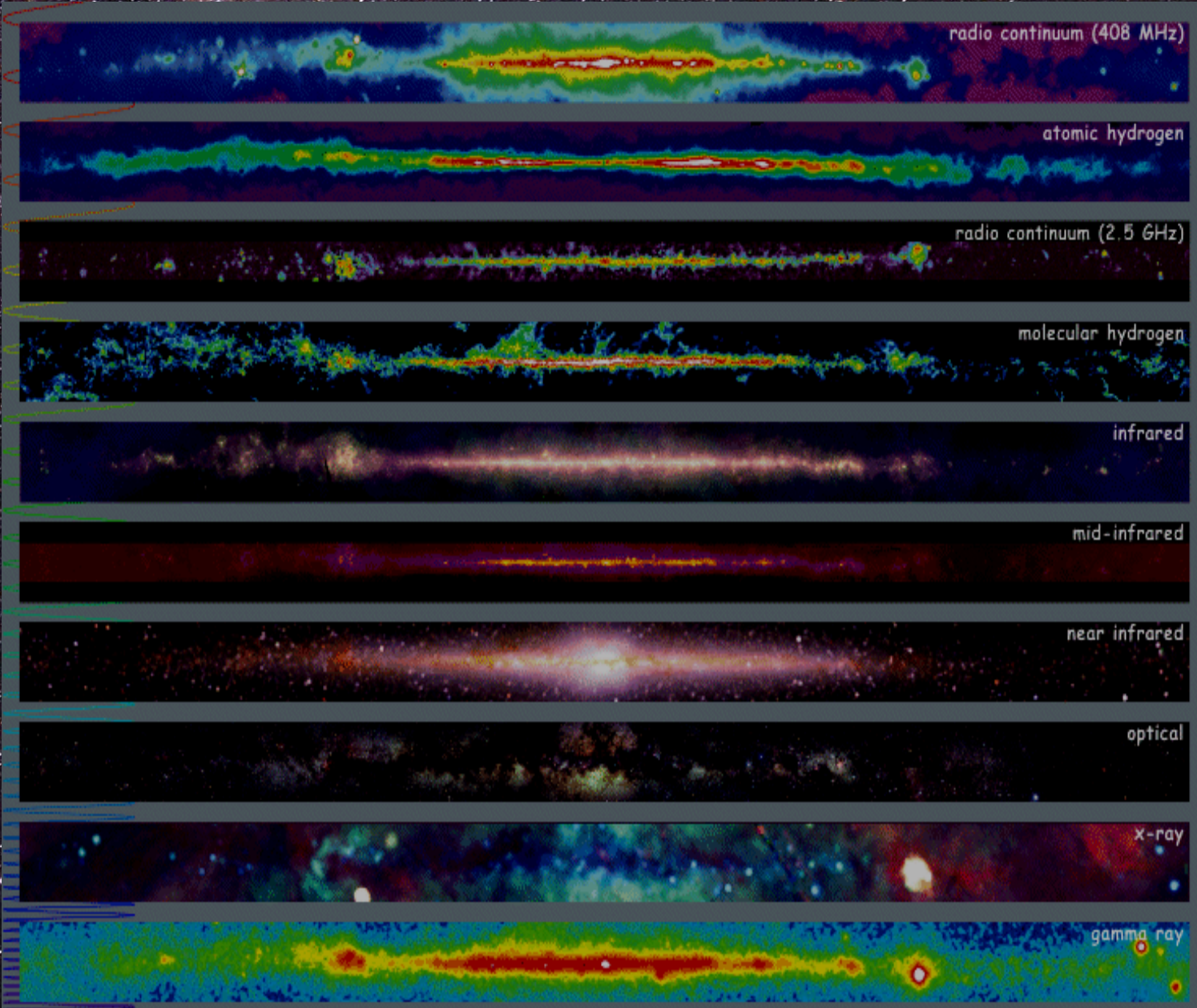

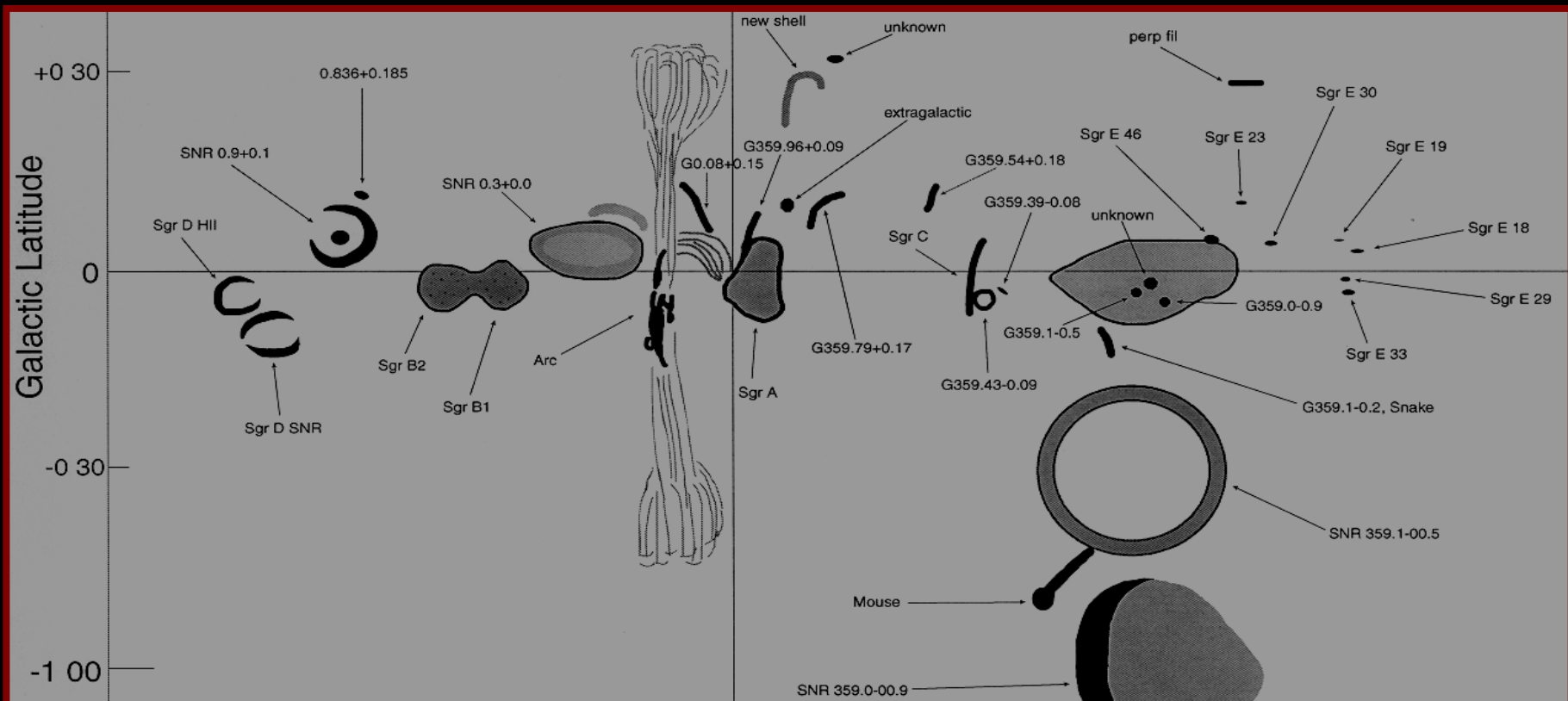
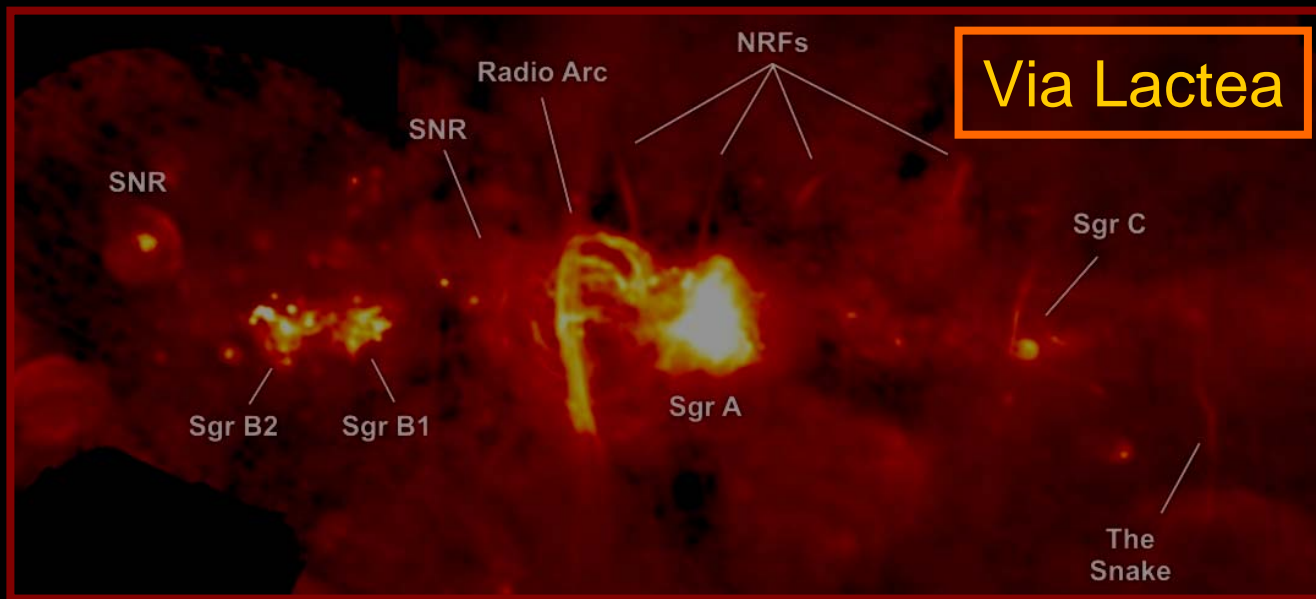

Centro de la Via Lactea

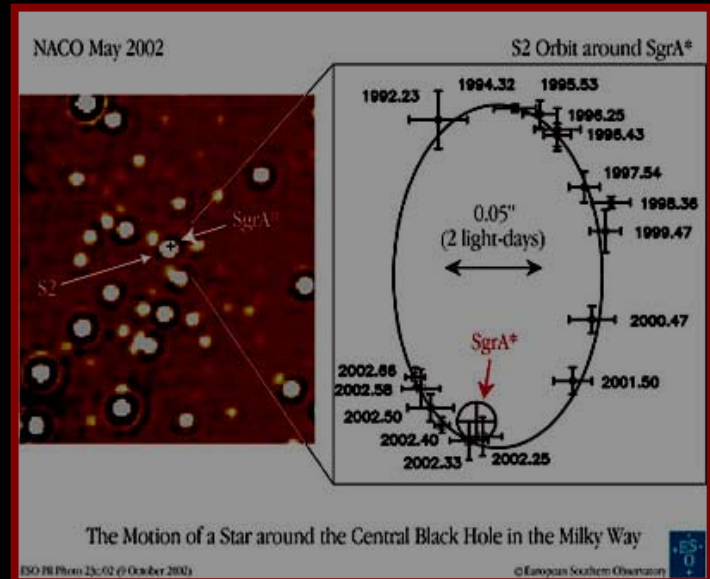
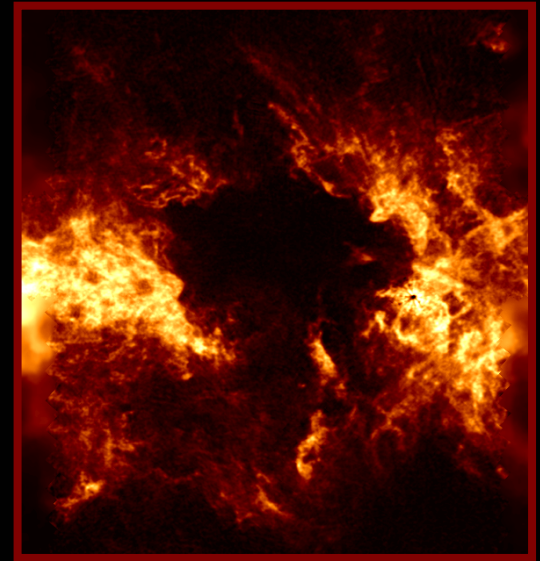
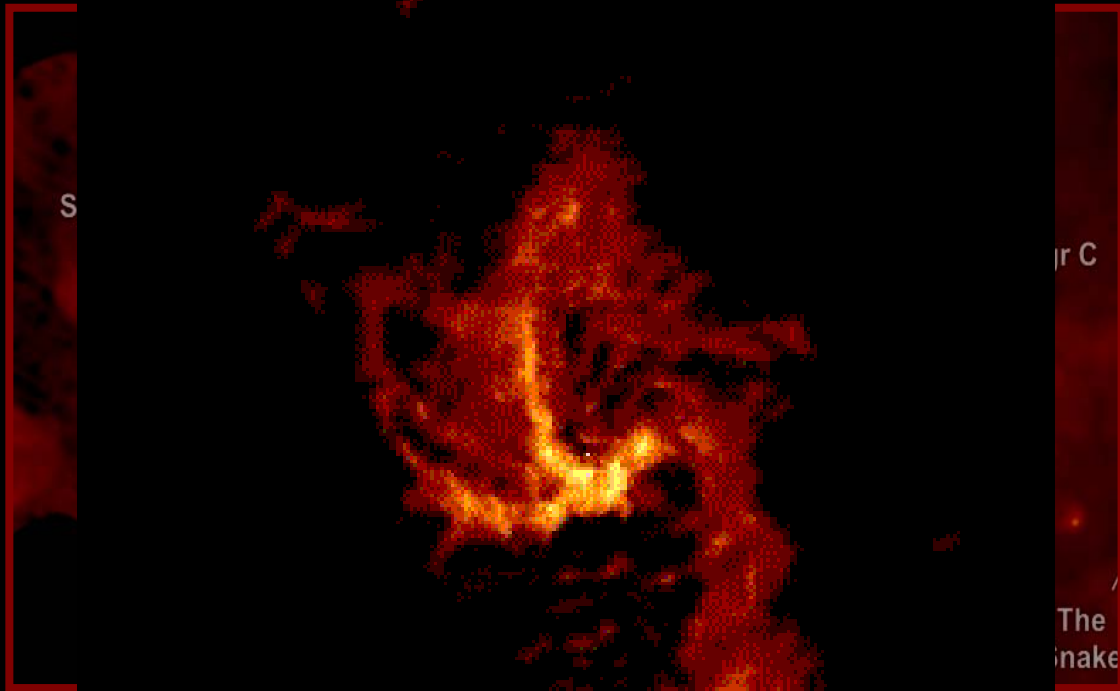



Viento Galactico en M82

M82 (Optico vs. Radio)

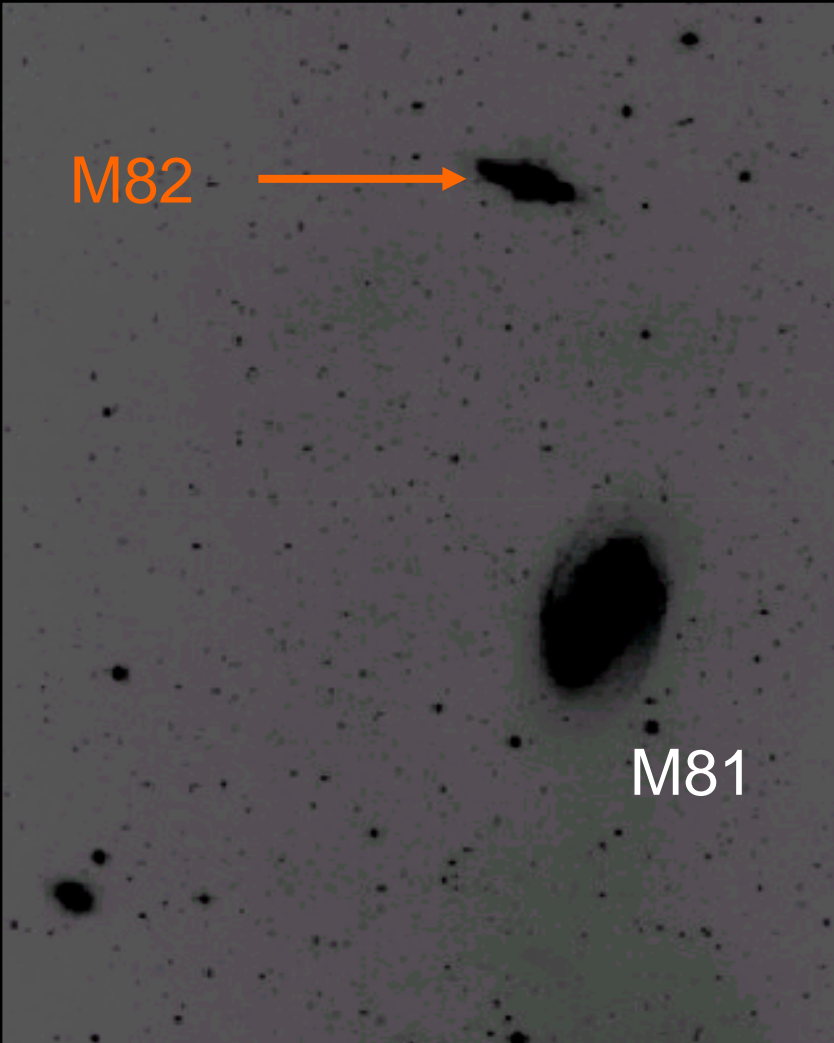

Optico

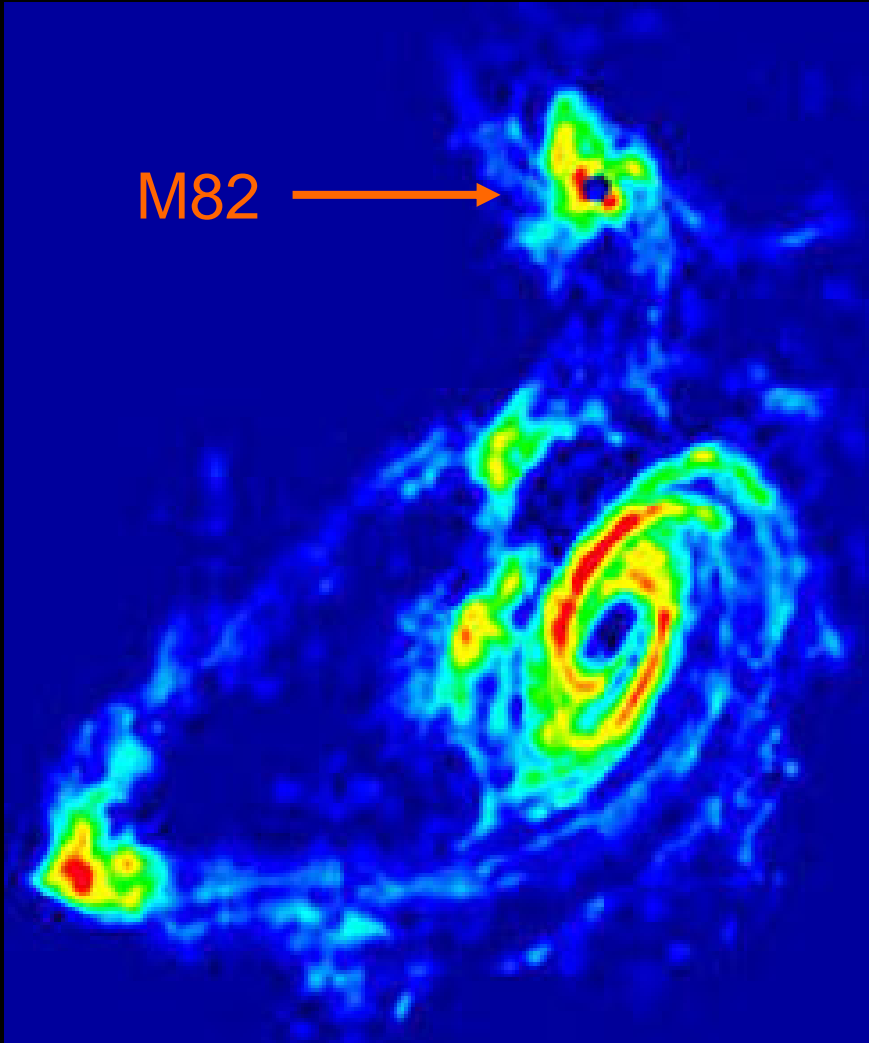

Radio

NGC 3079 (shell rota)

(a)

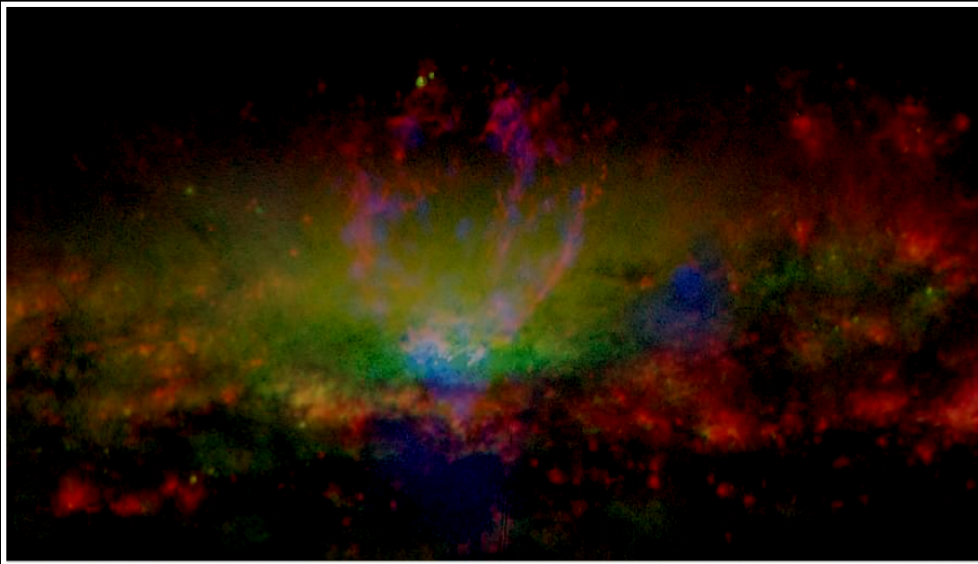
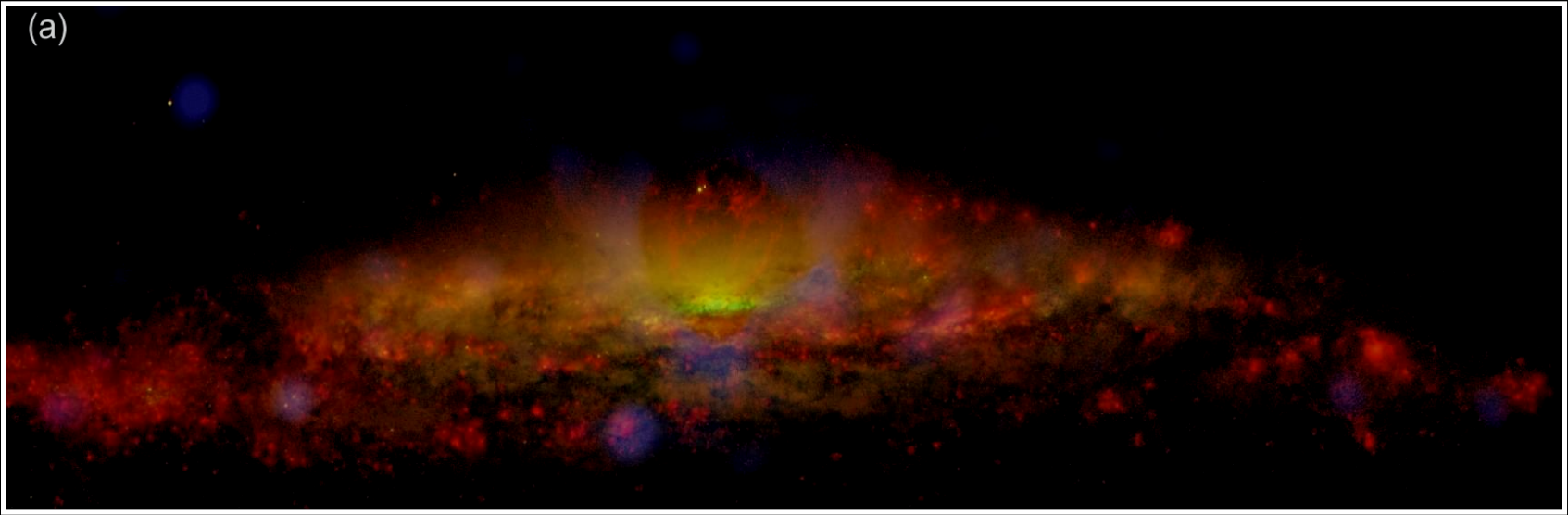

Universo Esponja (galaxias en la superficie de burbujas)

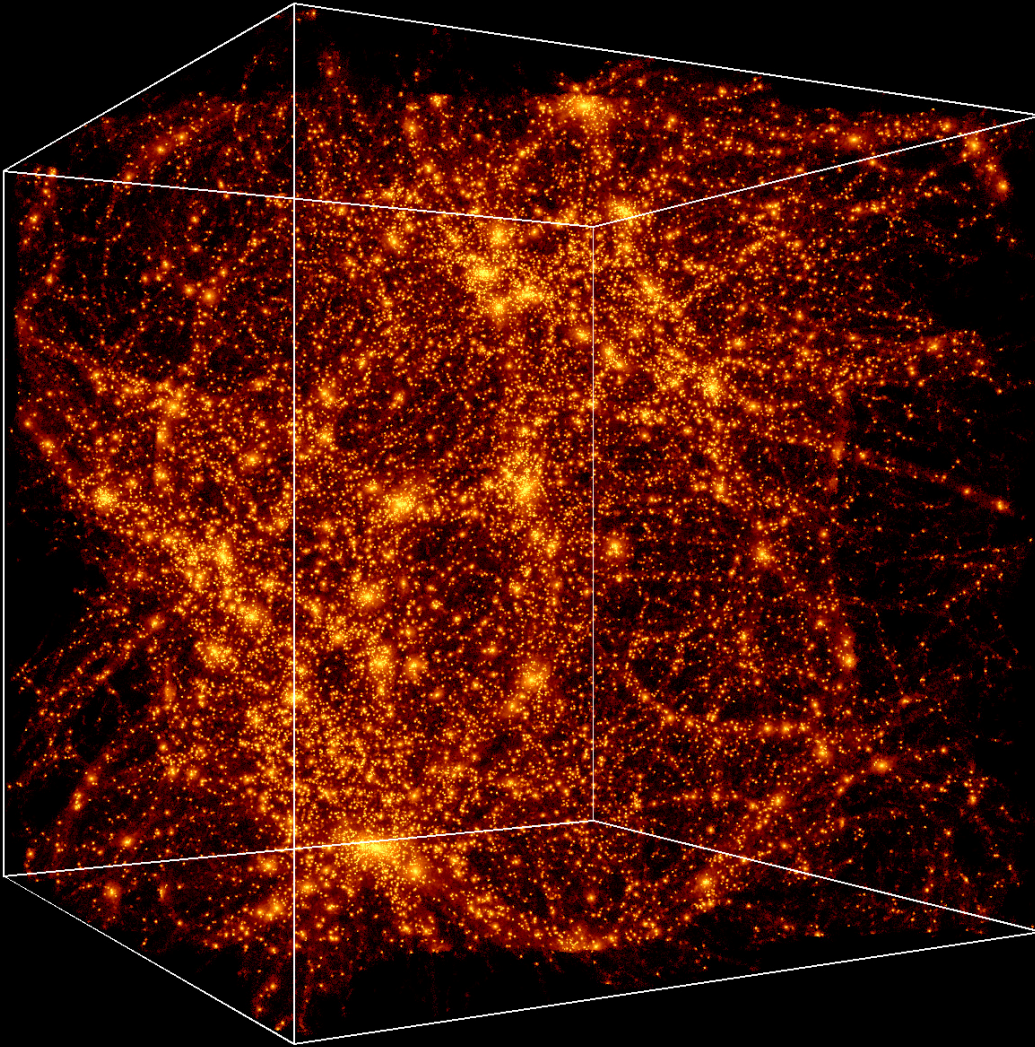

Simulaciones con Computadoras

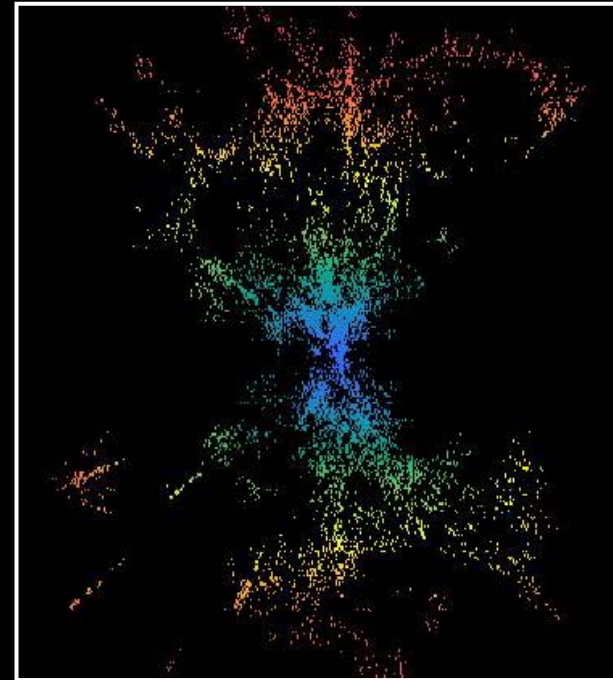

Observaciones

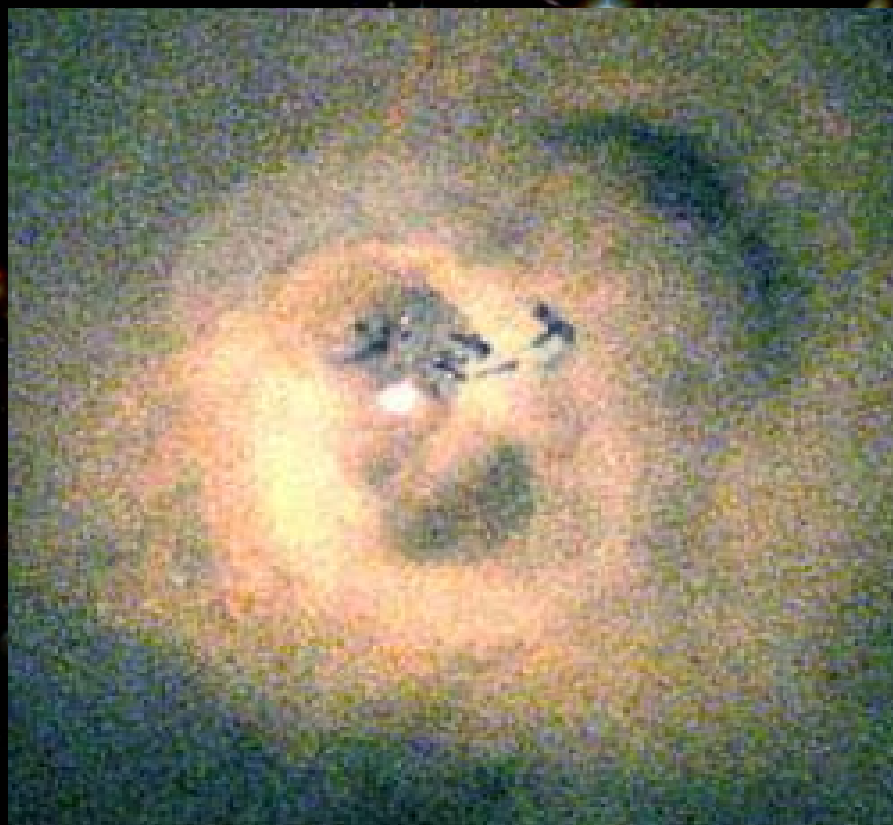

Centro de un Cumulo de Galaxias (Perseus)

**El Universo EXPLOSIVO/ACTIVO
(y el Cosmos/Kosmos)**

(VI) Explosiones en QSOs/AGNs

RADIO TELESCOP. 1960:
Radio - QSO

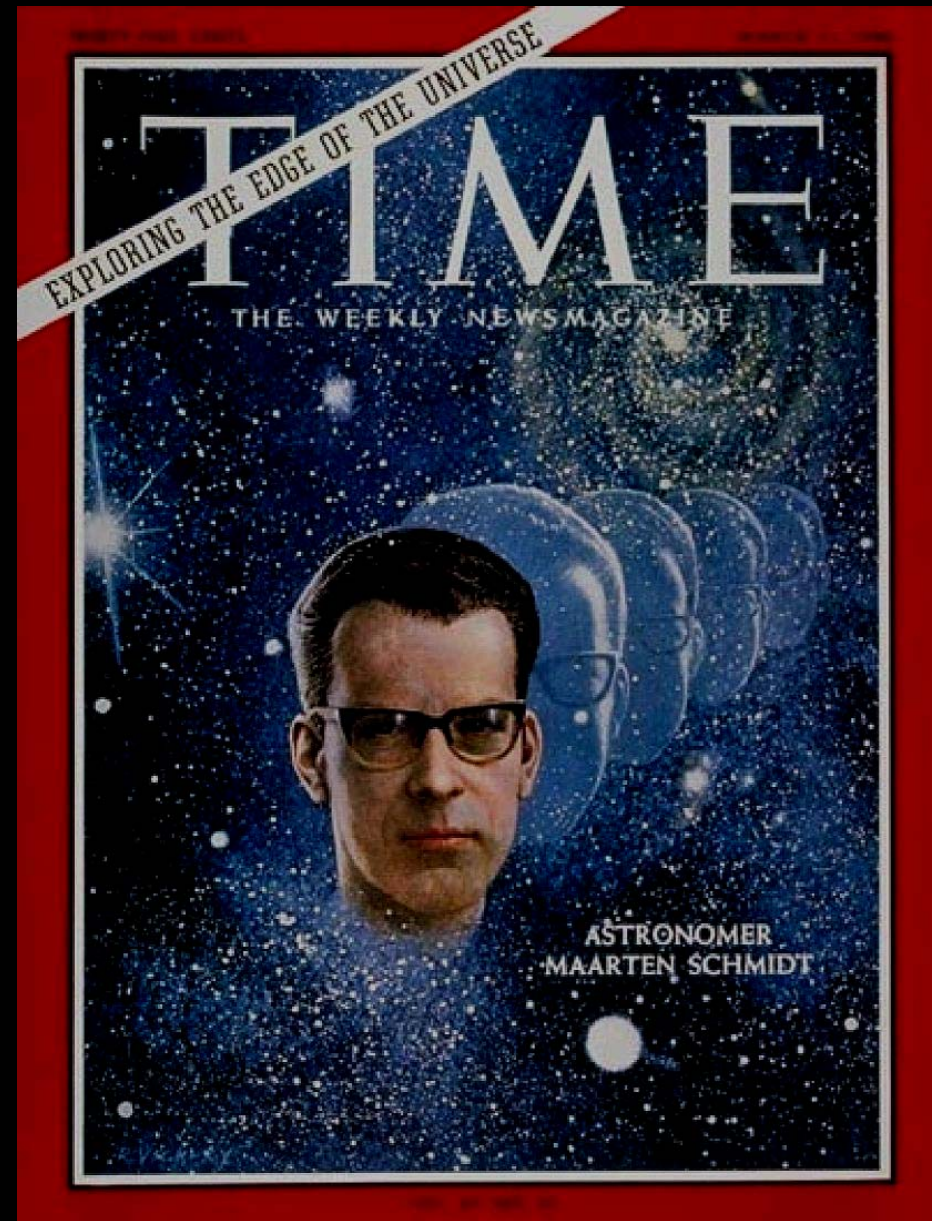

QSO 3C273 (imagen)

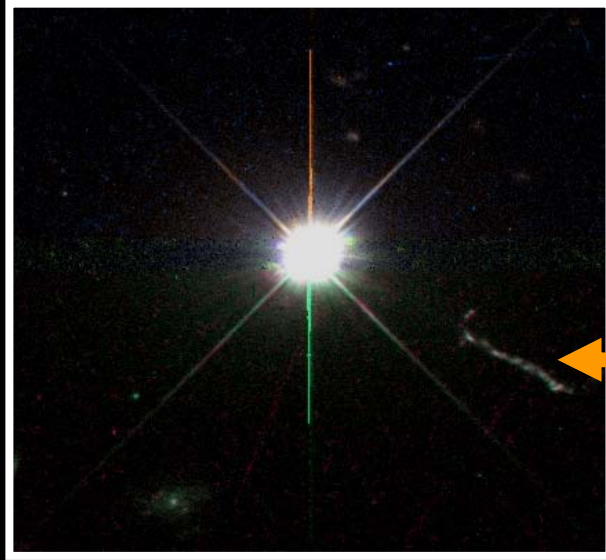

Jet

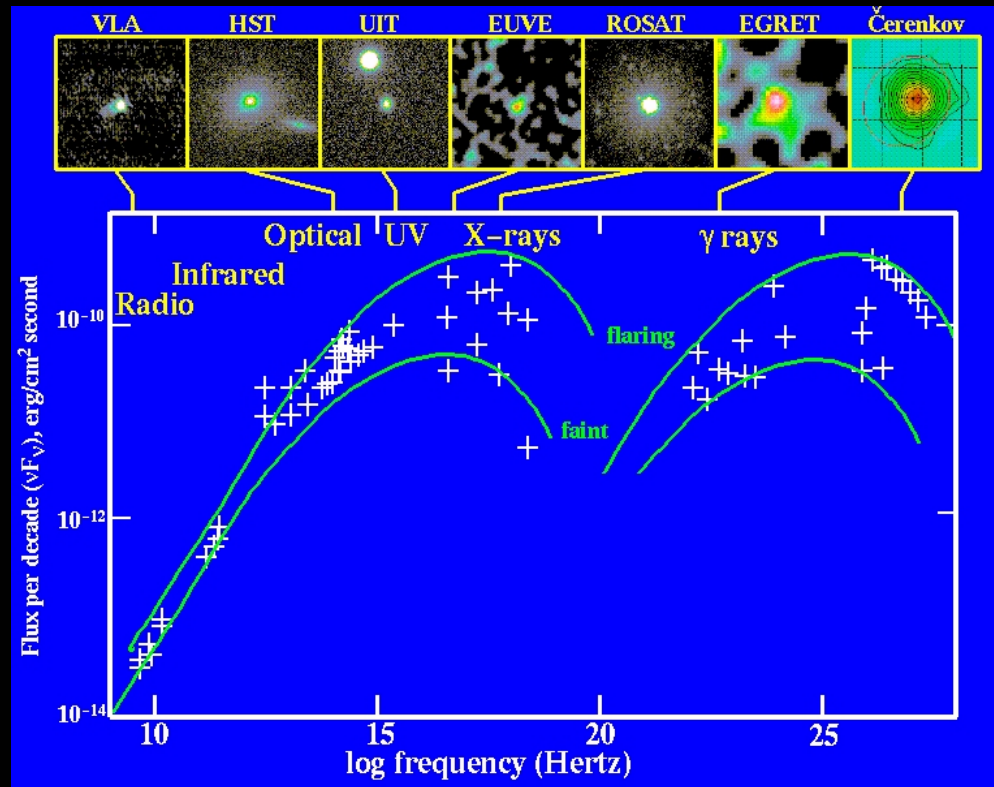
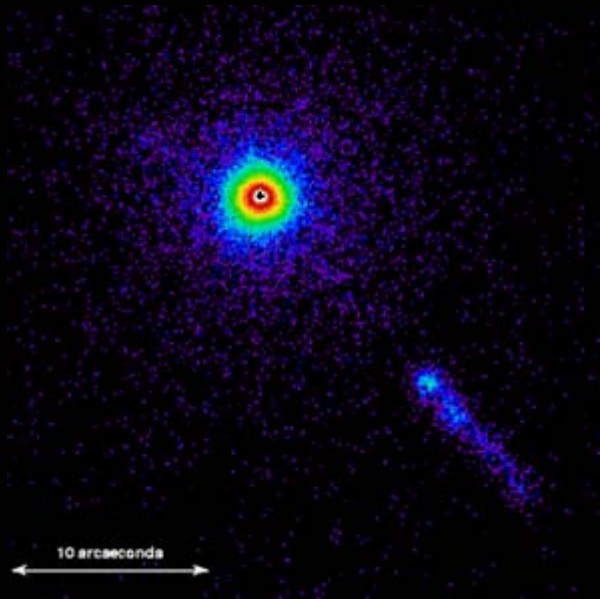

QSO 3C273 (espectro)

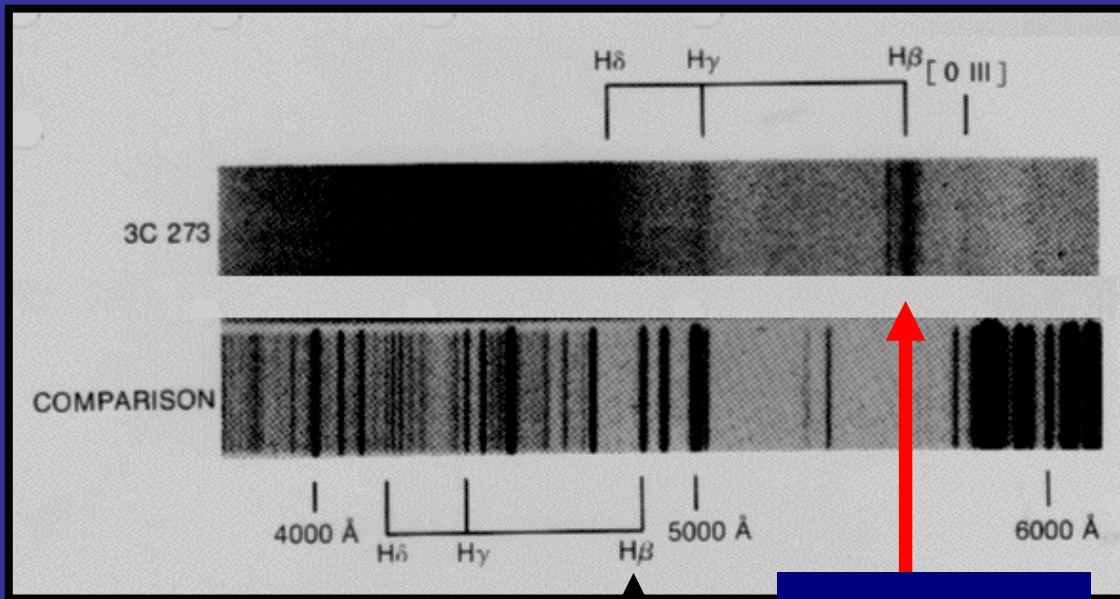

Redshift

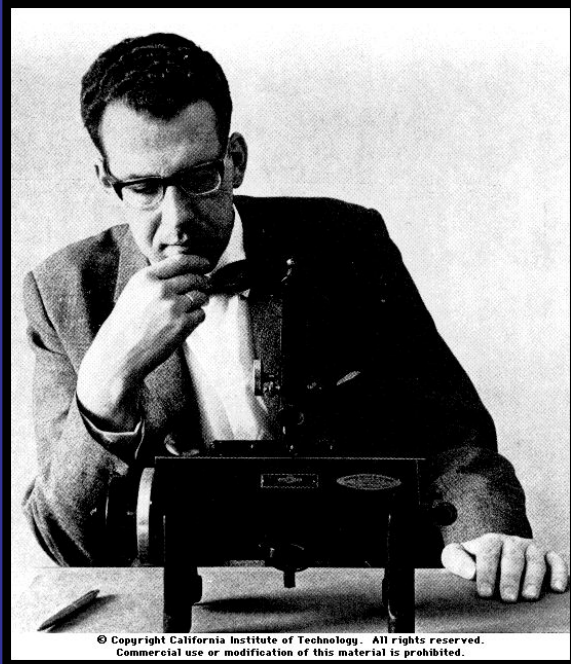

© Copyright California Institute of Technology. All rights reserved. Commercial use or modification of this material is prohibited.

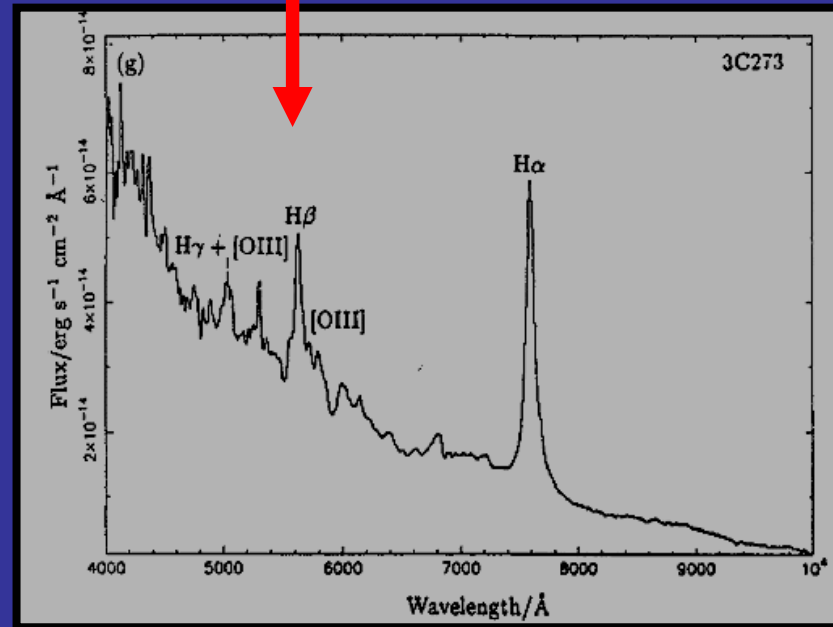

QSOs - AGNs

NGC 1068

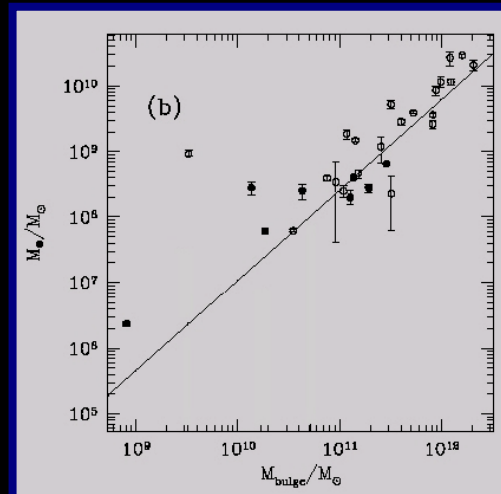
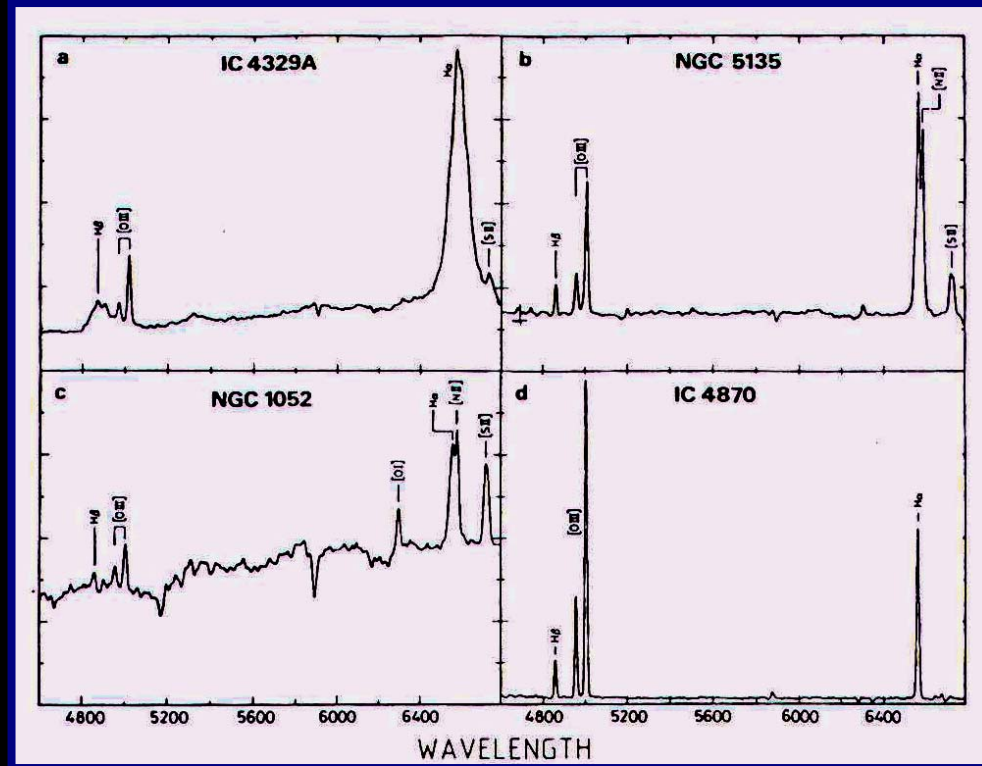
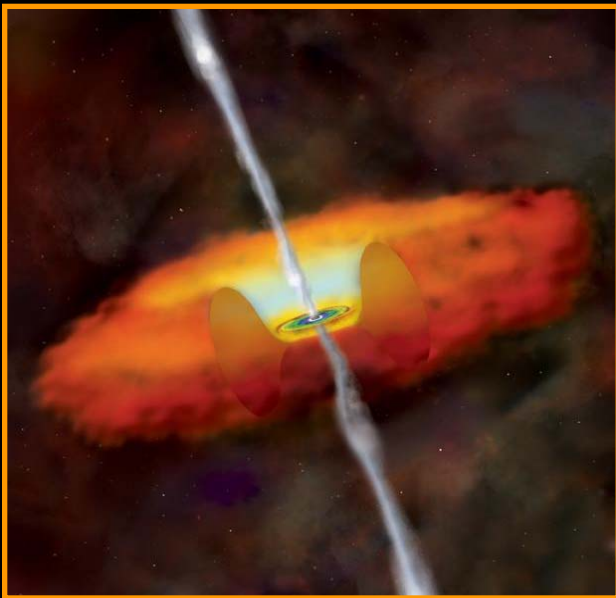

BAL QSOs (Lineas de Absorcion)

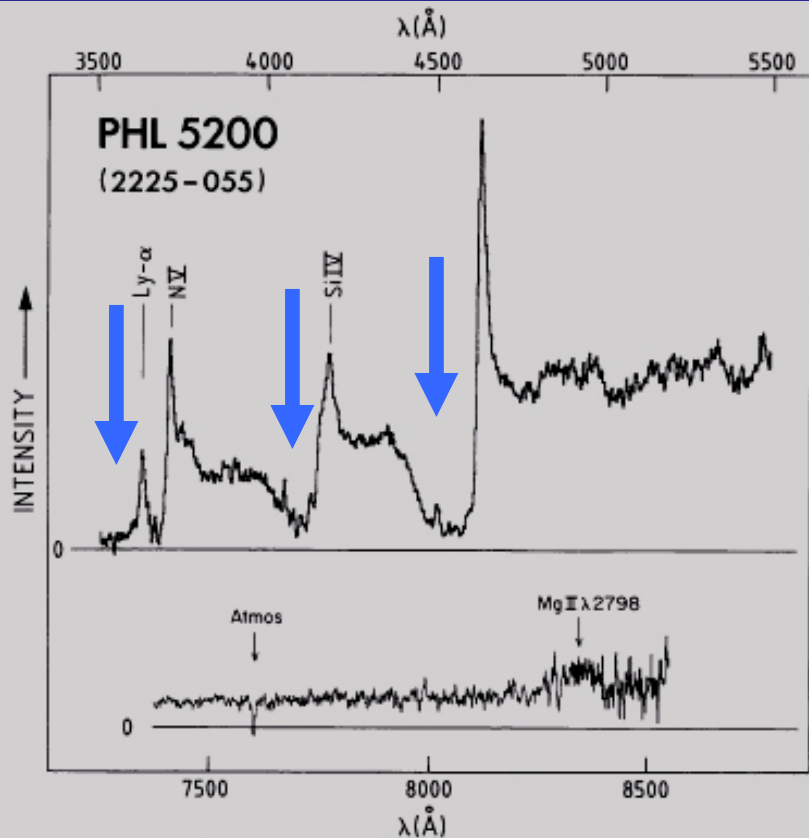

The spectrum of PHL 5200

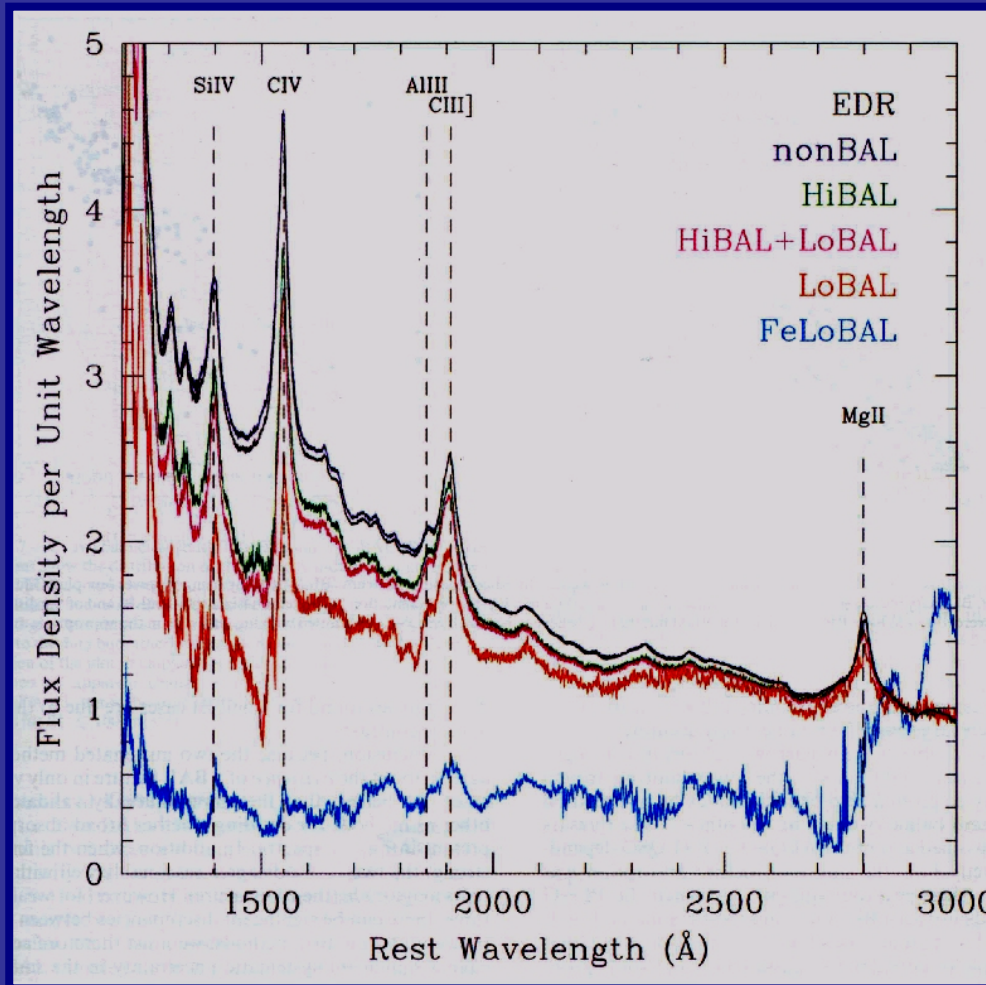

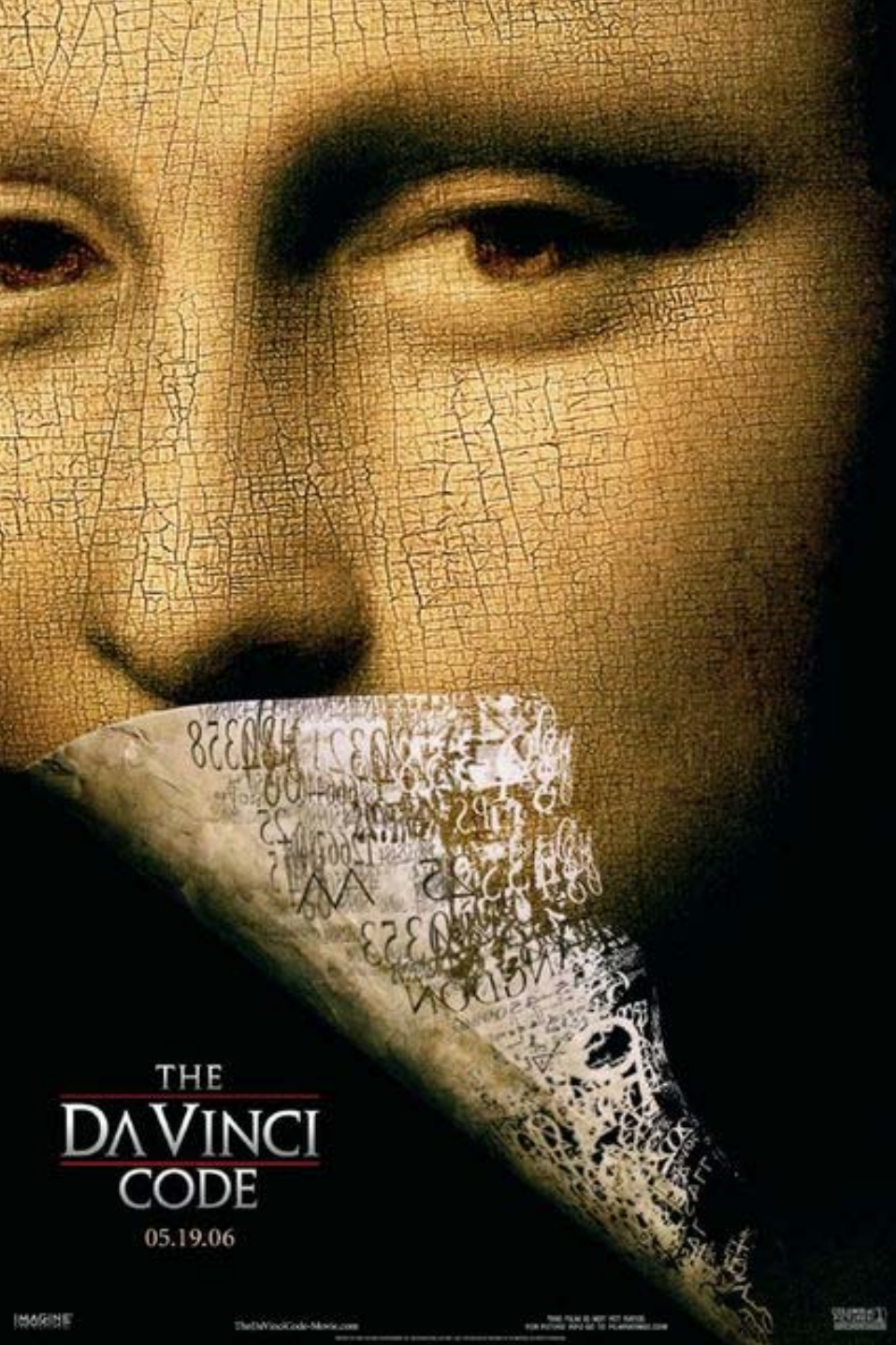

“QSO EVOLUTION
is something of a
Holy Grail, because
we know almost
nothing about it”.

F. HAMANN (2003)

THE
DA VINCI
CODE

05.19.06

Modelo Explosivo de Formacion de Galaxias y QSOs

Ikeuchi (1981, QSO), Ostriker & Cowie (1981, galaxies):
after $z = 100$ small seed perturbation collapses,
giving giant explosive release from Population III of Massive Stars

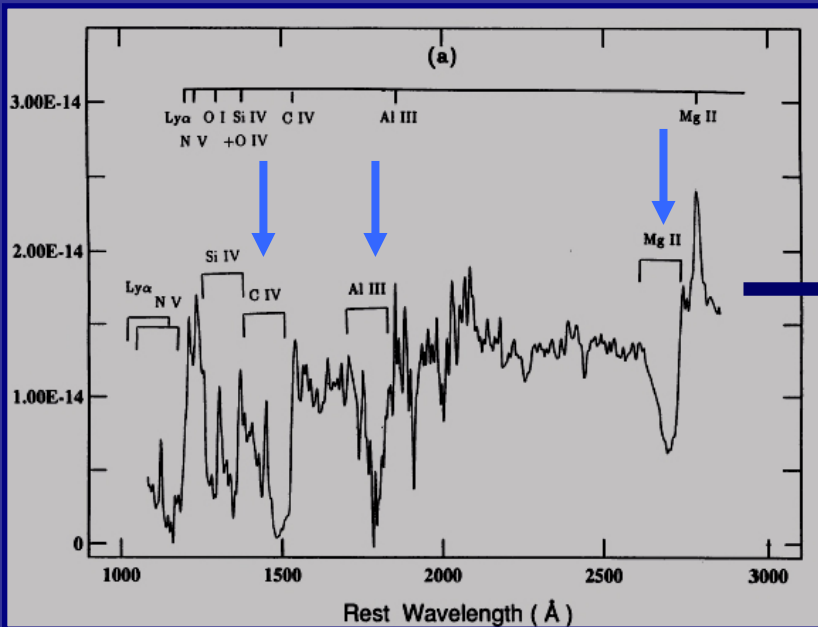

**Hazar, Terlevich
et al. (1984)**

**Heckman, et al.
(1990)**

**Lipari, Terlevich
et al. (1993/4, ...)**

**Modelo
Explosivo**

Zahan & Collin (1999, QSOs):
In Accretion Disk the Star formation is similar to Pop. III, with Explosion

PROGRAMAS DE OBSERVACION:

**(1.a) IR QSOs/Mergers +
Out-Flow (Low Z)**

La Palma WHT 3D – Gemini 3D

CASLEO

B. Alegre - CAHA

HST – CTIO – ESO/NTT

**(1.b) BAL + IR + Fe II QSOs/Mergers
(Low Z)**

Gemini-GMOS 3D

IUE - HST

KPNO - CASLEO

ESO-NTT y 3.6m

**(2) BAL QSOs & Ly α Emitters
(High Z)**

Gemini- GMOS 3D

SDSS

Subaru+Keck

ESO-VLT VIMOS

3D - IFU Spectrosc.

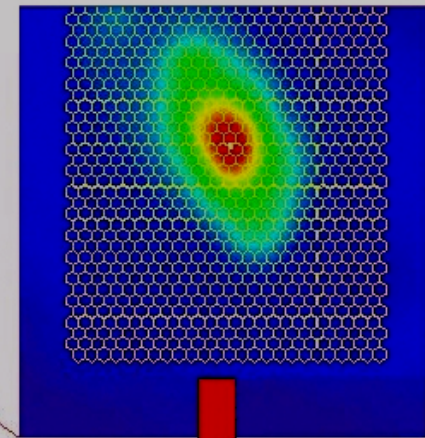

The IFU records a spectrum for each element

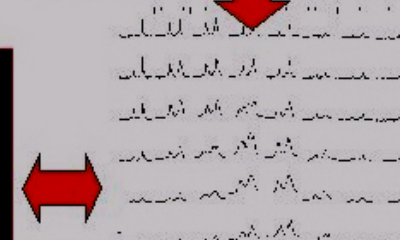
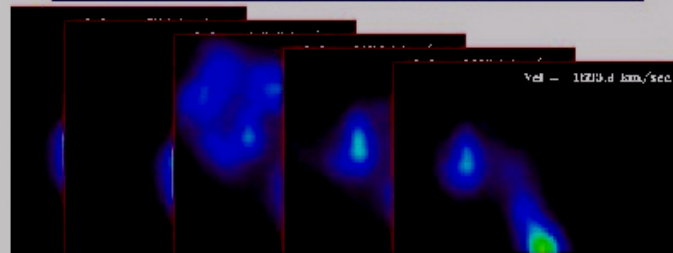

One spectrum for each element (only 4% shown)

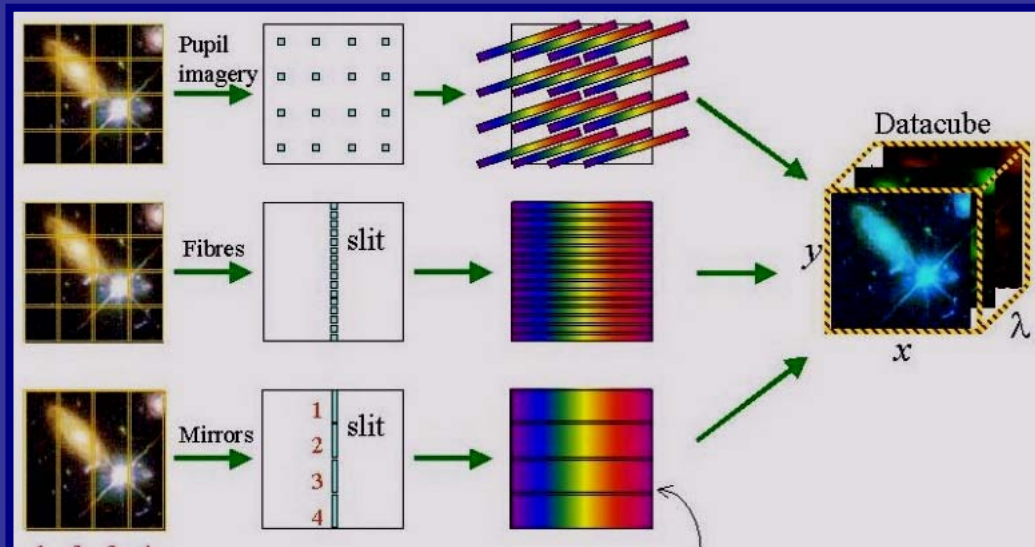





ESO



Hawaii



Gemini South



LaPalma

IFU-3D

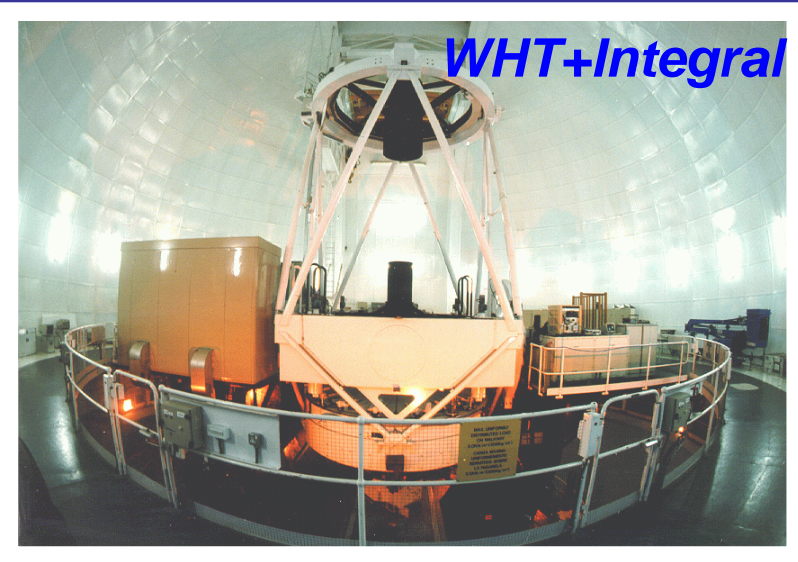
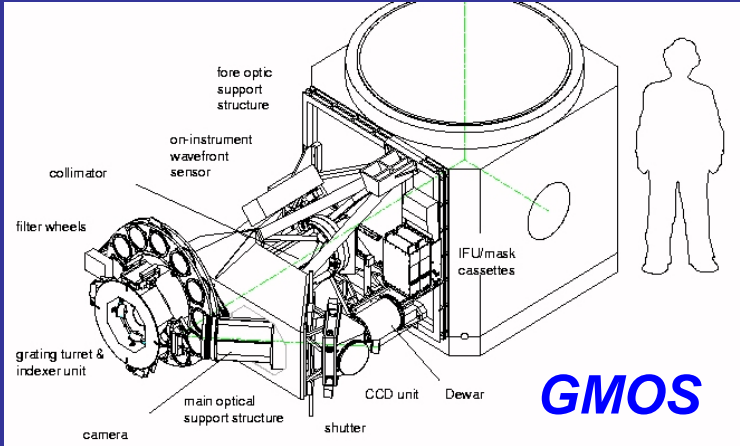

IFU-3D

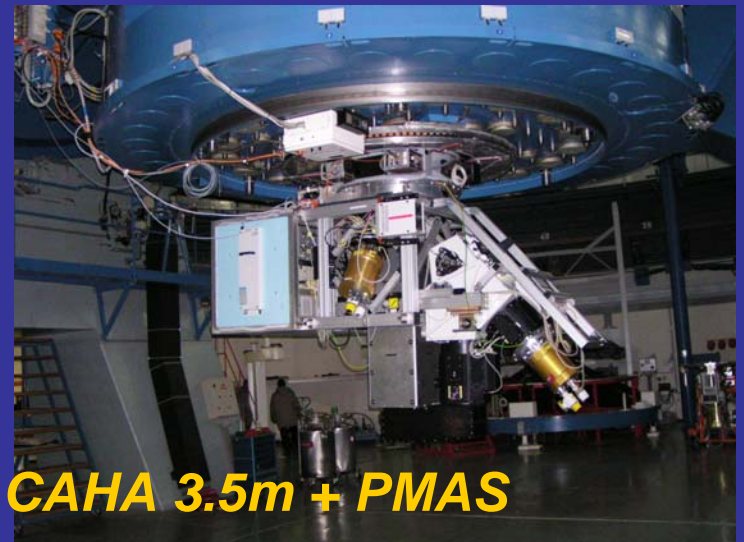
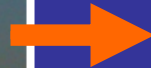
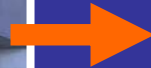

HST

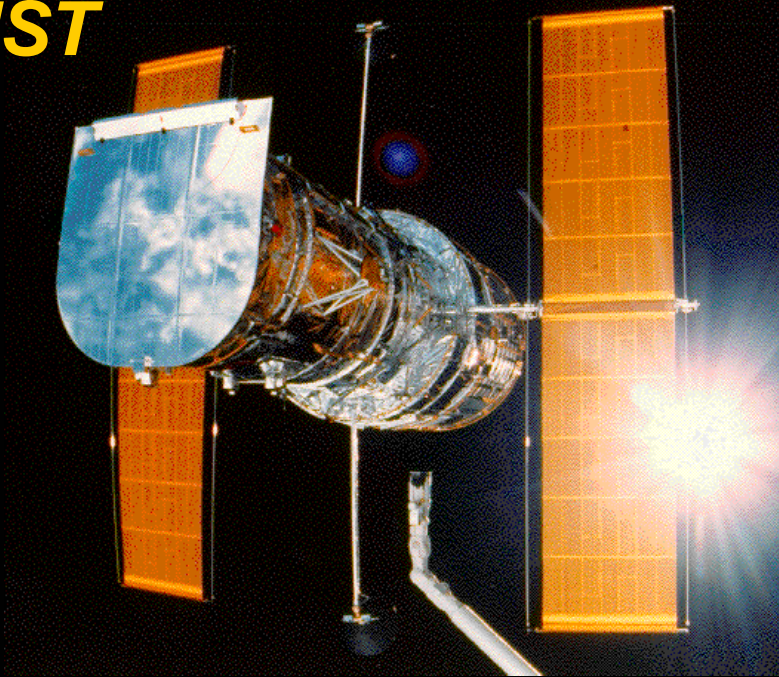

IRAS



IUE



ISO



SIRFT



BAL QSO Models: with Out-Flow

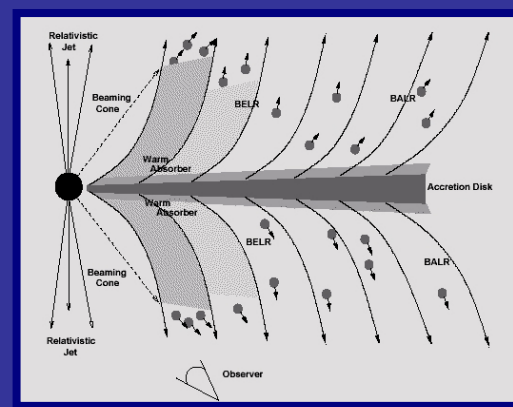
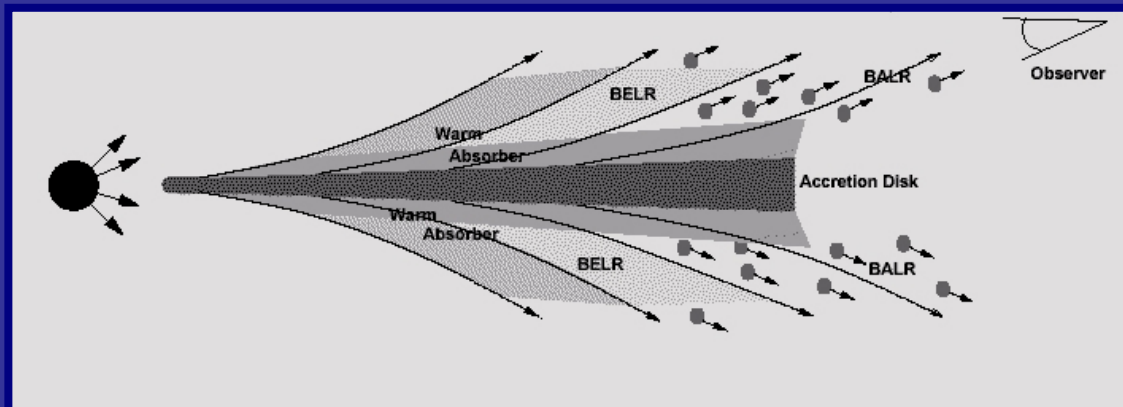
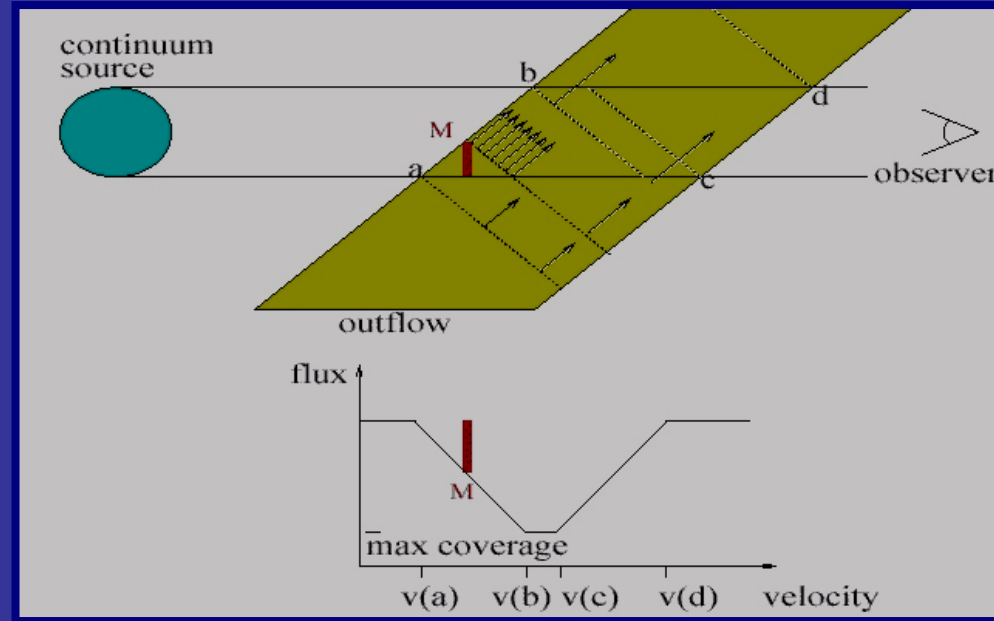
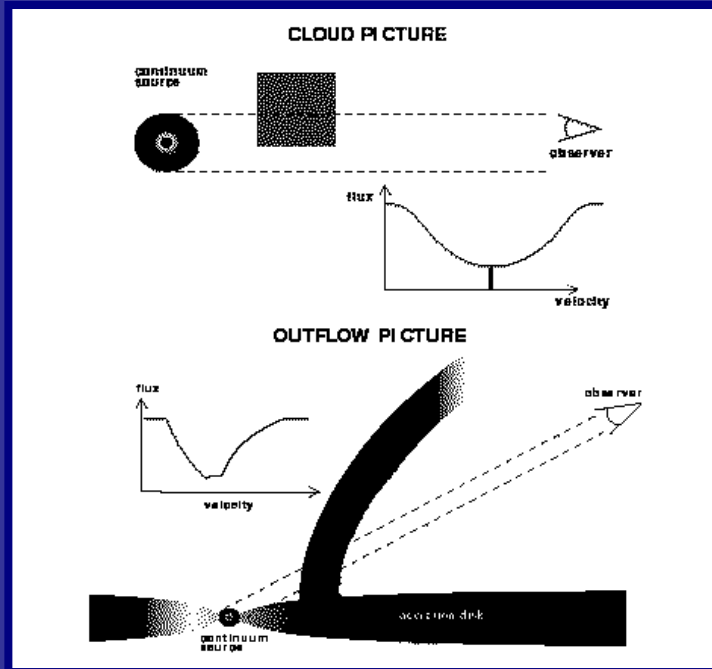

Arab et al. (1997, 2000, 2003)

Composite Models for BAL QSOs: Black Hole + Accretion Disk + StarBurst

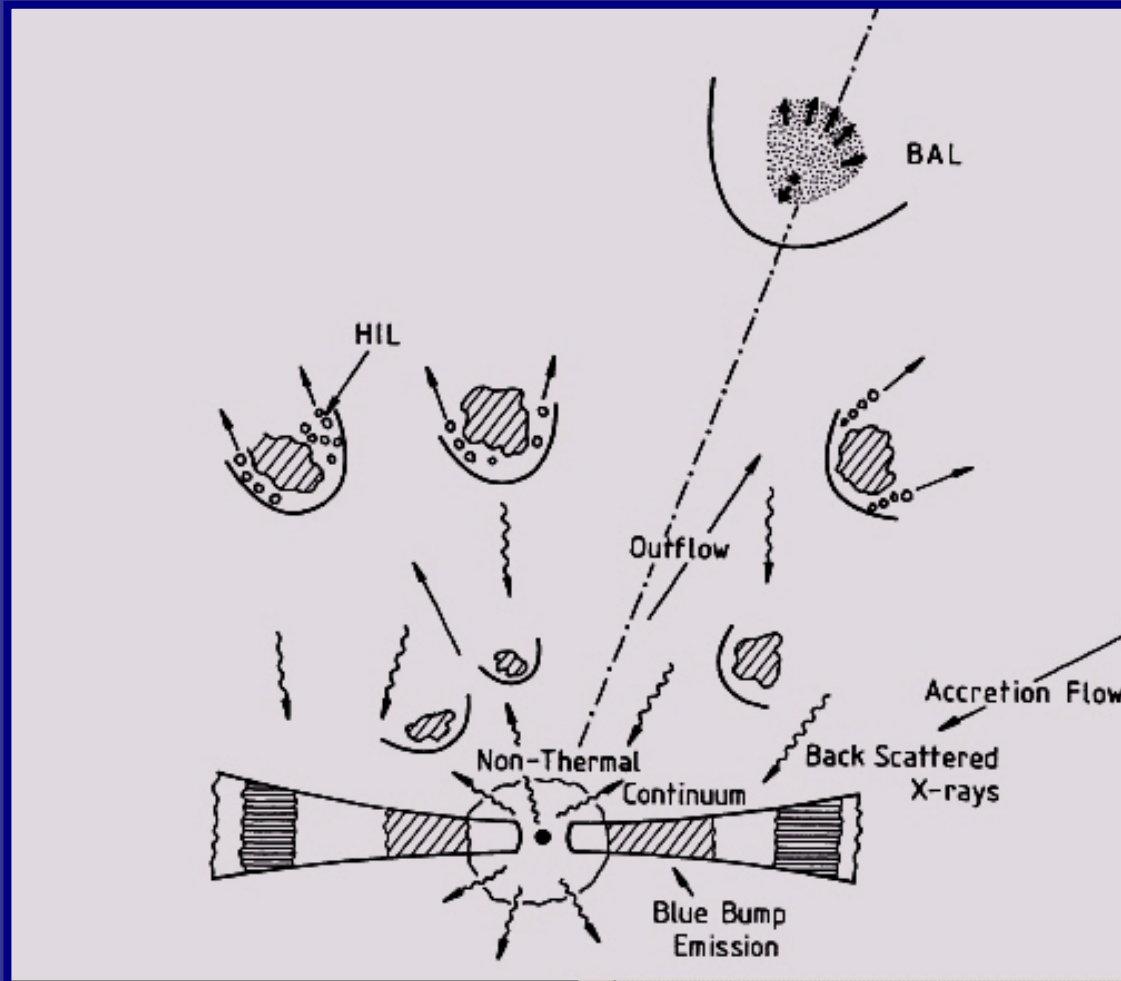

Modelo de Perry & Dyson (1992a,b)

IR + BAL + Fe II QSO (AGN+SB): Merger Mrk 231

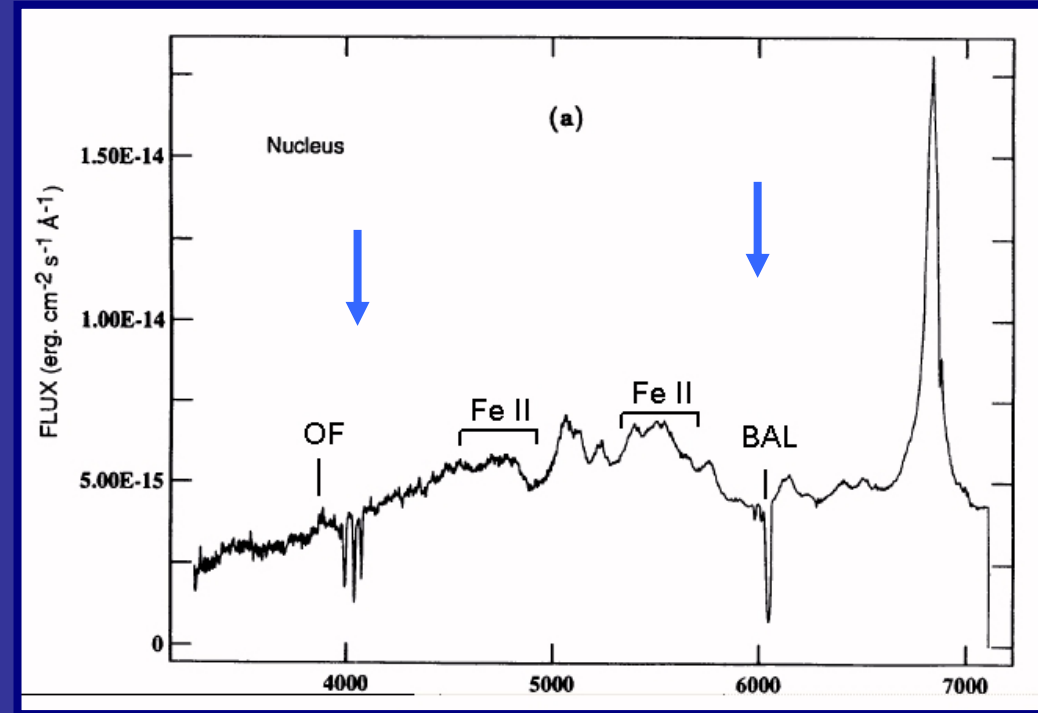
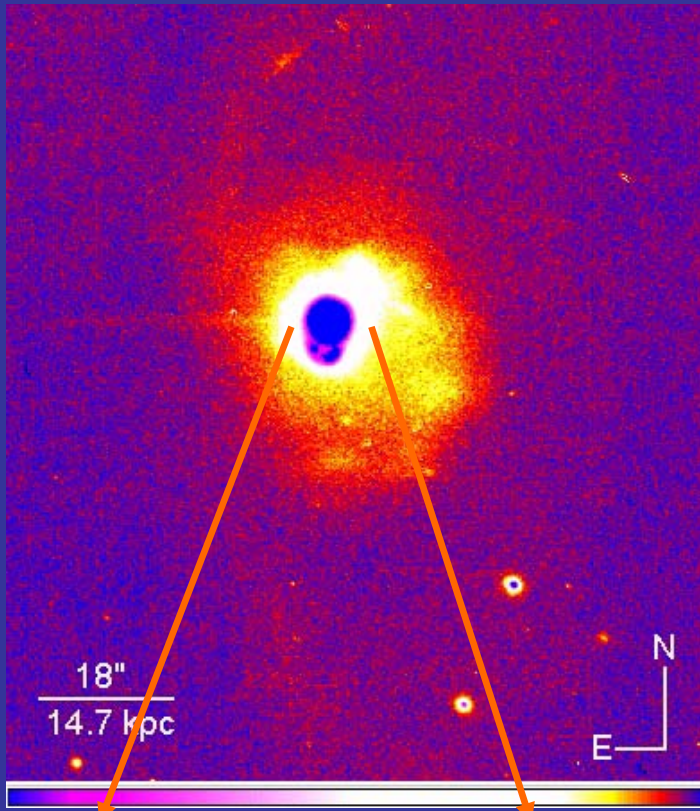

Lipari et al. (1994)

IR + BAL + Fe II QSO (AGN+SB): Merger IRAS07598+6508

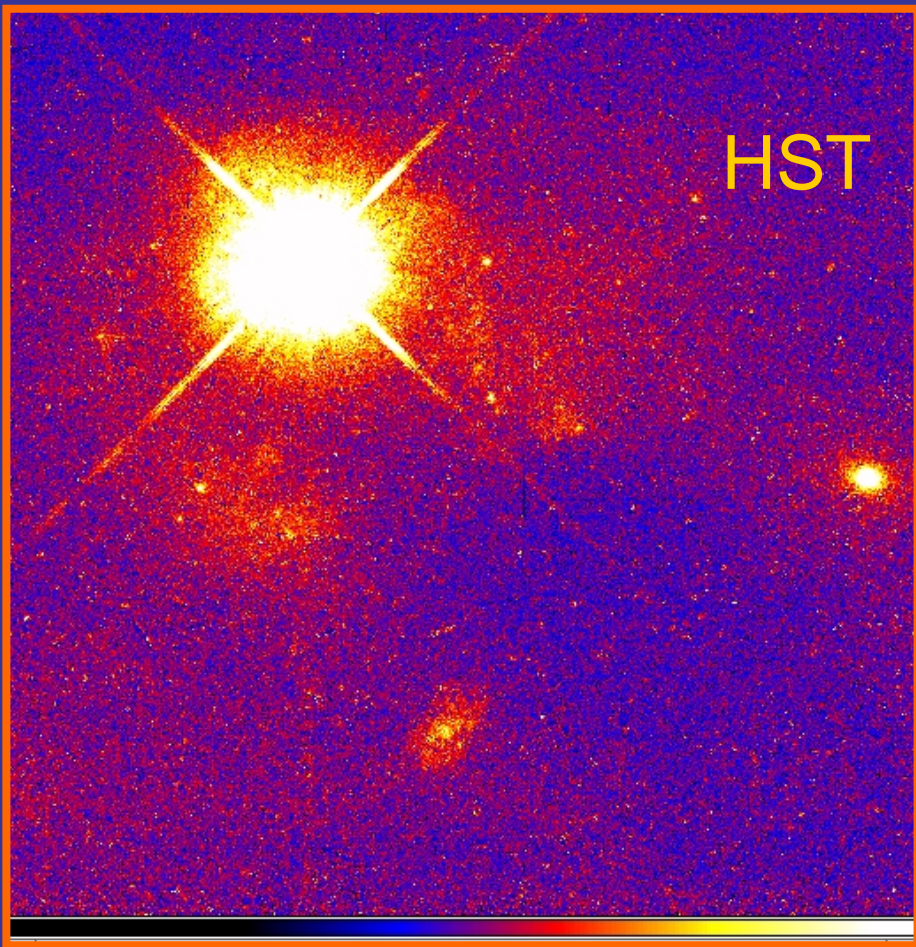

Lipari (1994)

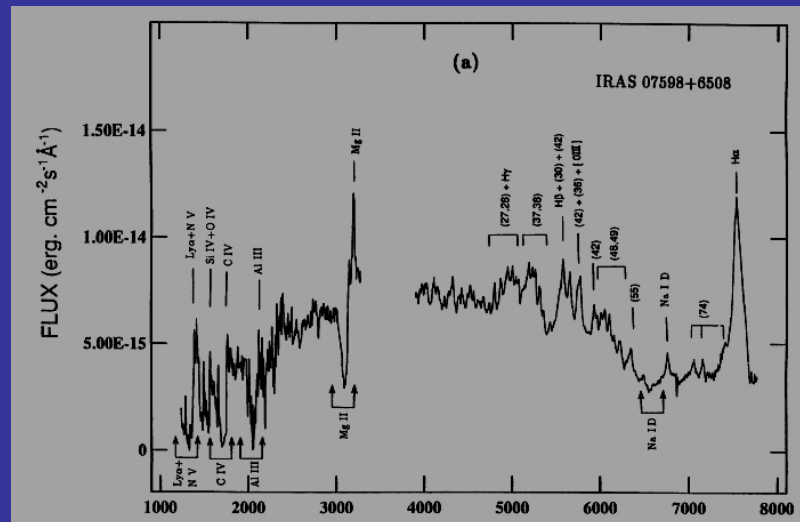
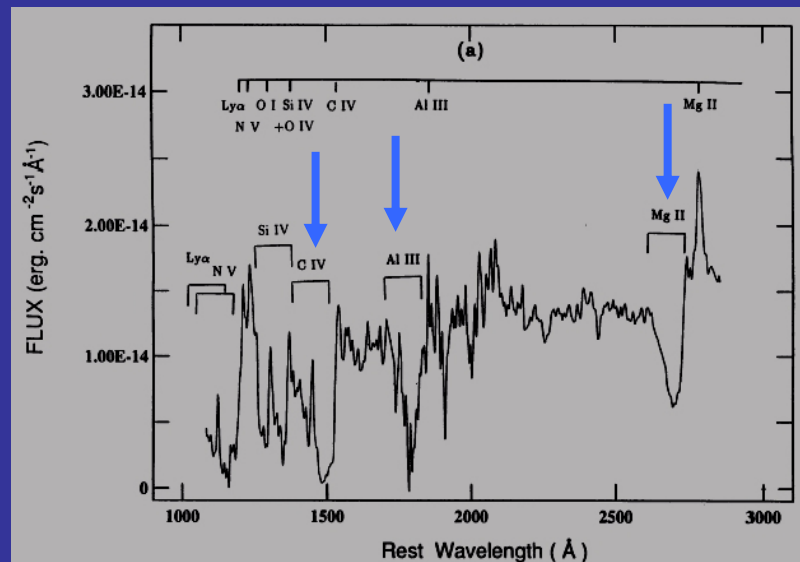

BAL en IR+Fe II QSOs: 27%

IR Color-Color Diagram (1994)

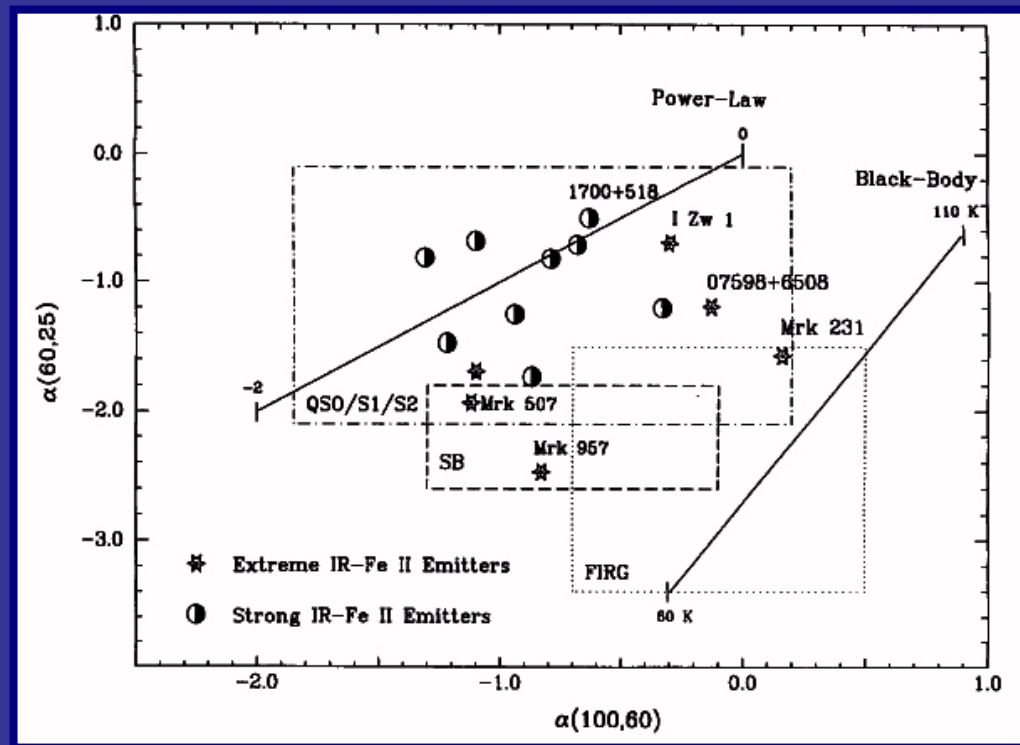

Evolutionary Paths

Joseph et al:



(i) merger \rightarrow giant shocks \rightarrow superstarbursts + GWs \rightarrow elliptical galaxies;

Sanders et al:



(ii) merger \rightarrow H₂-inflow (starbursts) \rightarrow cold ULIRGs \rightarrow warm ULIRGs + QSOs;

Lipari et al:



(iii) merger/s \rightarrow extreme starburst + GW (inflow + outflow) \rightarrow IR + Fe II + BAL composite/transition QSOs \rightarrow standard QSOs and ellipticals \rightarrow ?

Evolutionary Model for Composite QSOs

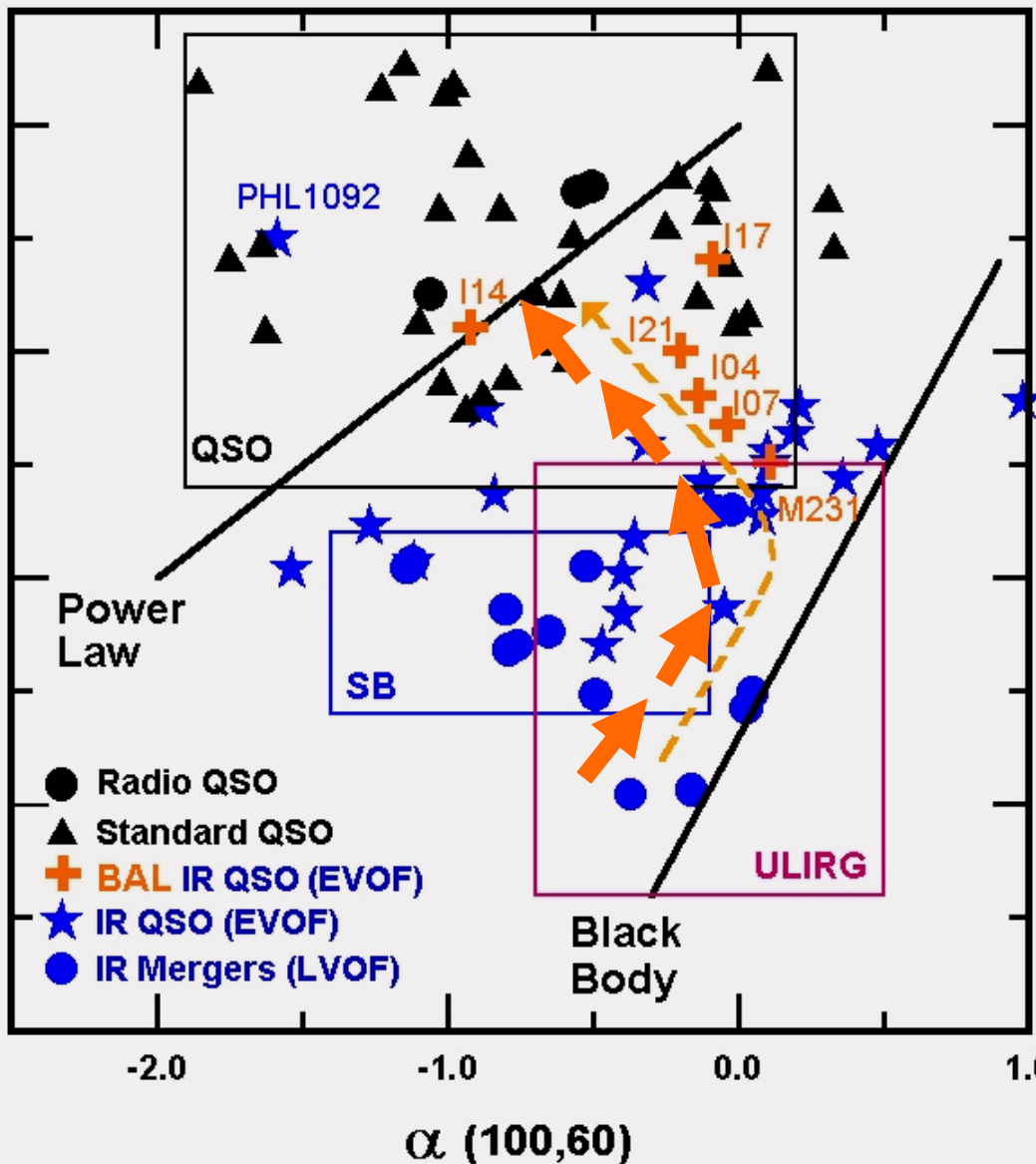

IR Color-Color Diagram of IR Mergers & QSOs

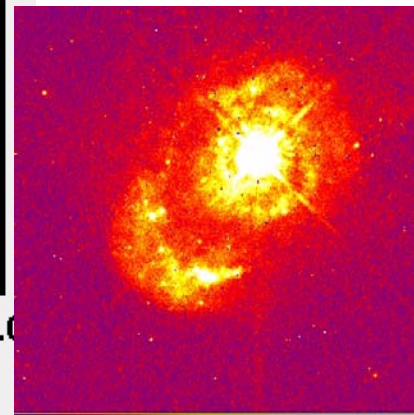
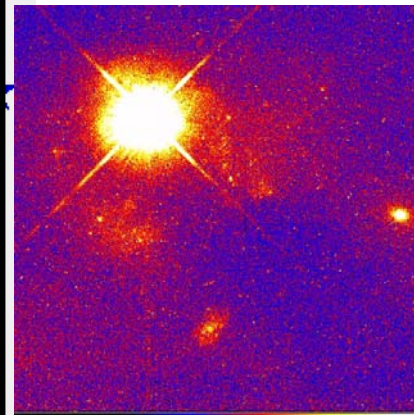
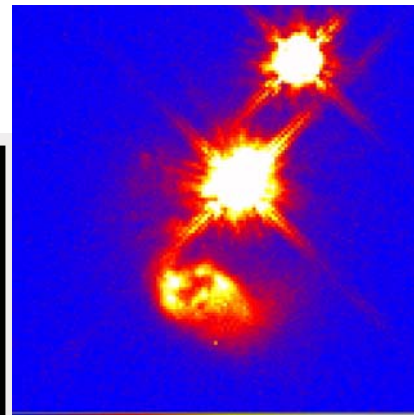
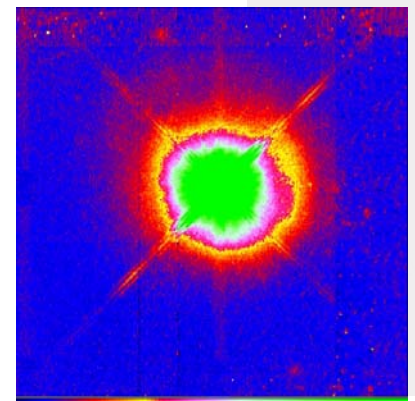
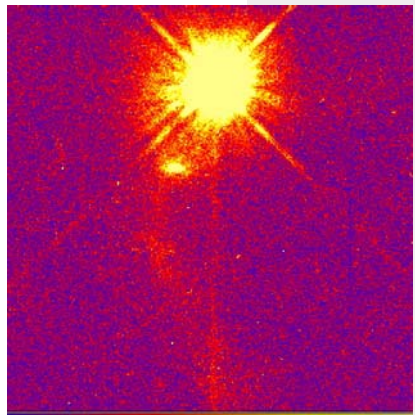
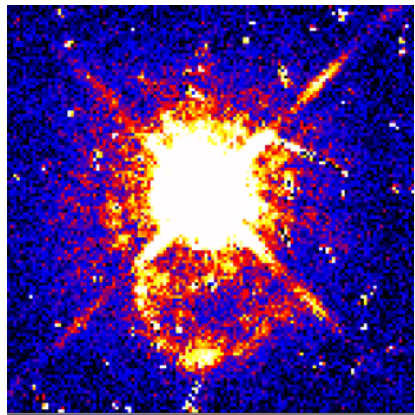

IR Merger Explosivo: NGC 5514

(Con una Burbuja gigante en la fase de “Ruptura”)

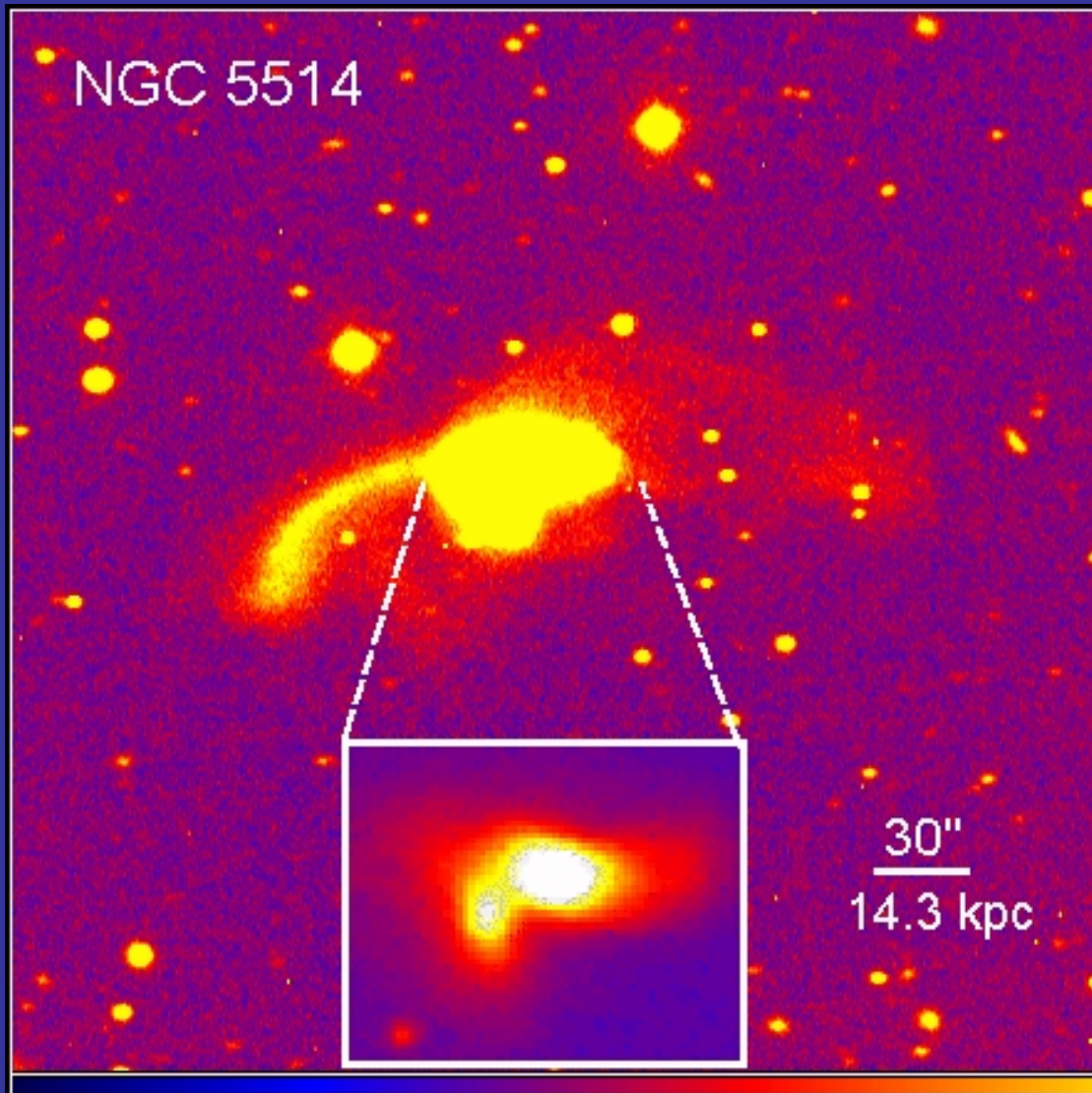

Lipari et al. (2004)

Imagenes 3D

Continuum $\lambda\lambda 6540-6640$ (Pos. 1, 2, 3)

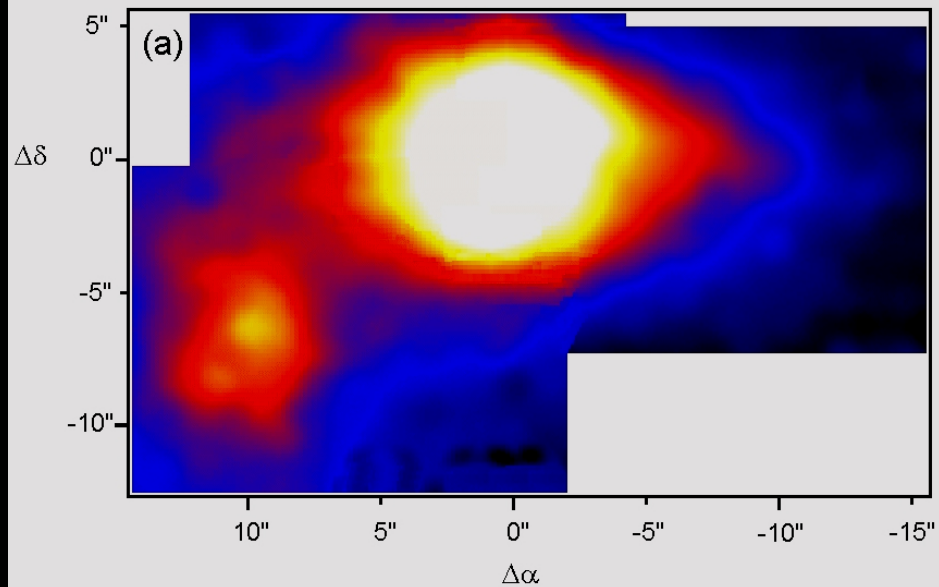

$H\alpha + [N II]$

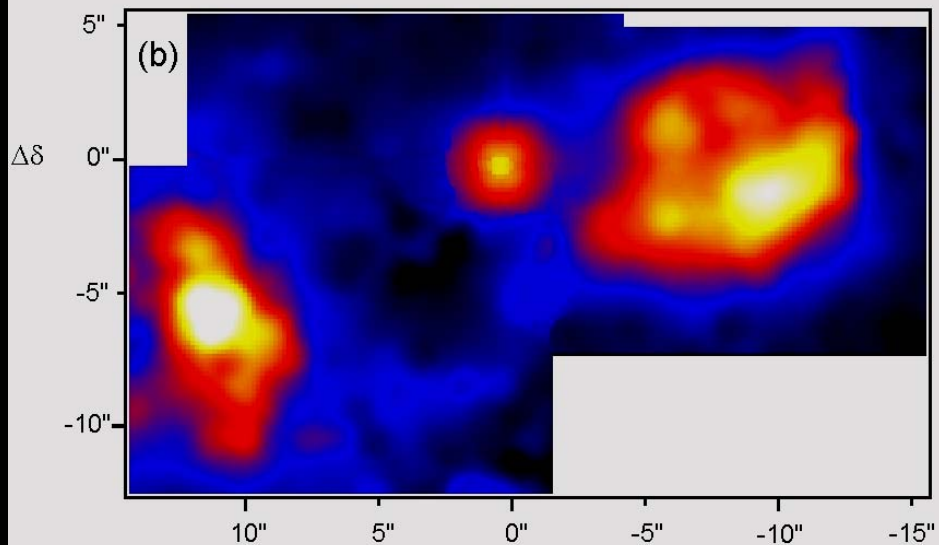

Mapas IFU-3D

Cinematica 3D

$[N II] \lambda 6583$ Velocity Field (Pos. 1, 2, 3)

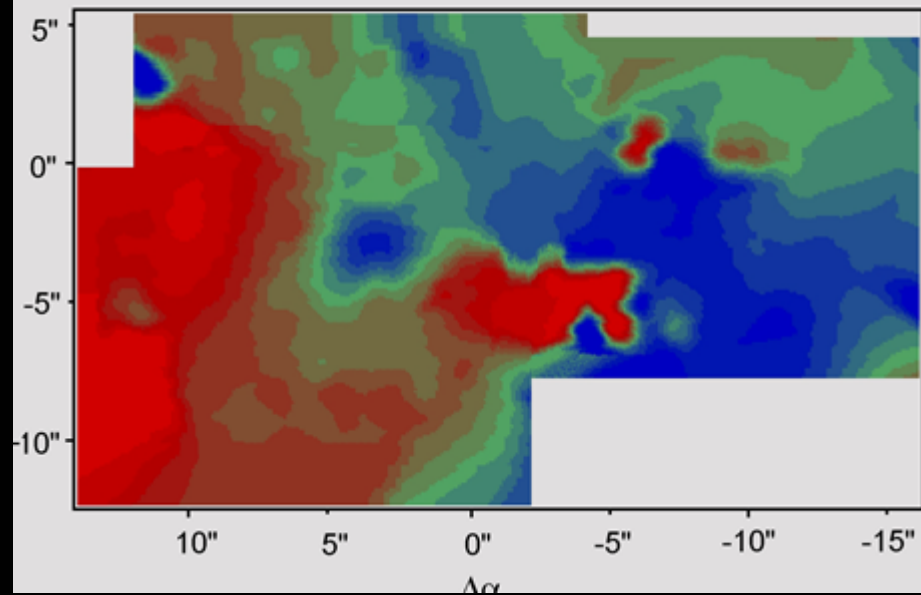

Multiple Nuclear Expanding Giant Shells-Bubbles in Mrk 231 (HST + 3D Gemini-WHT)

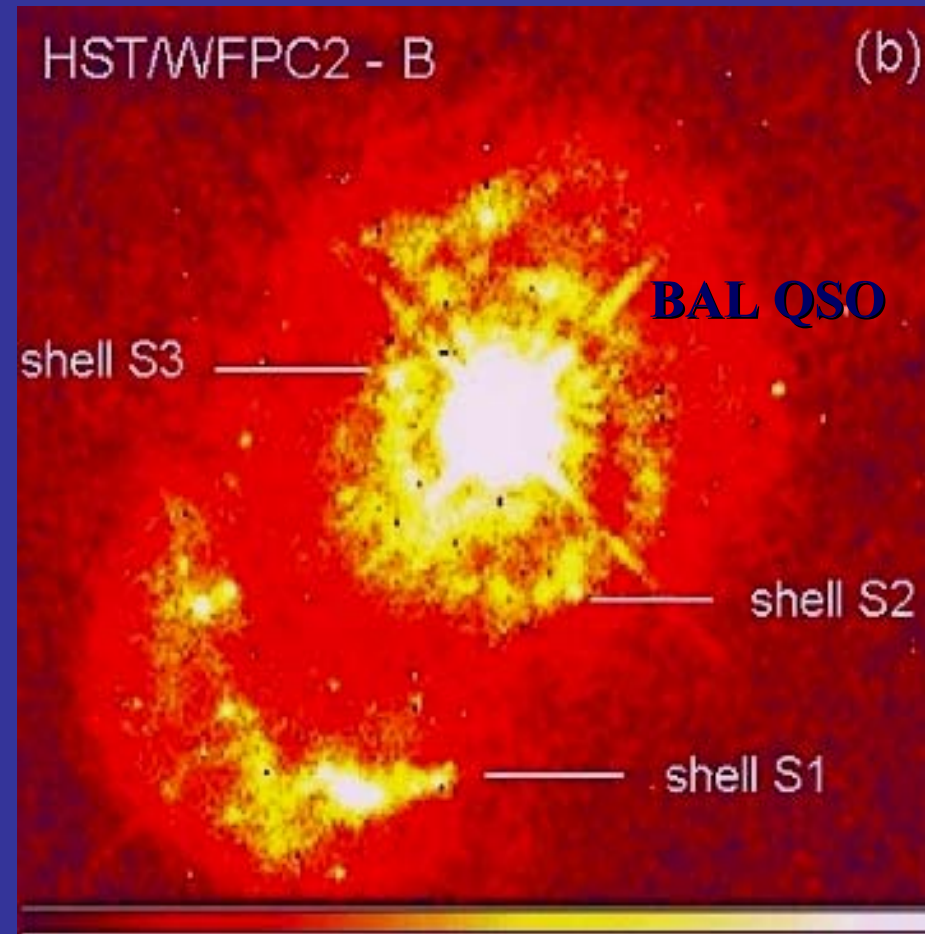
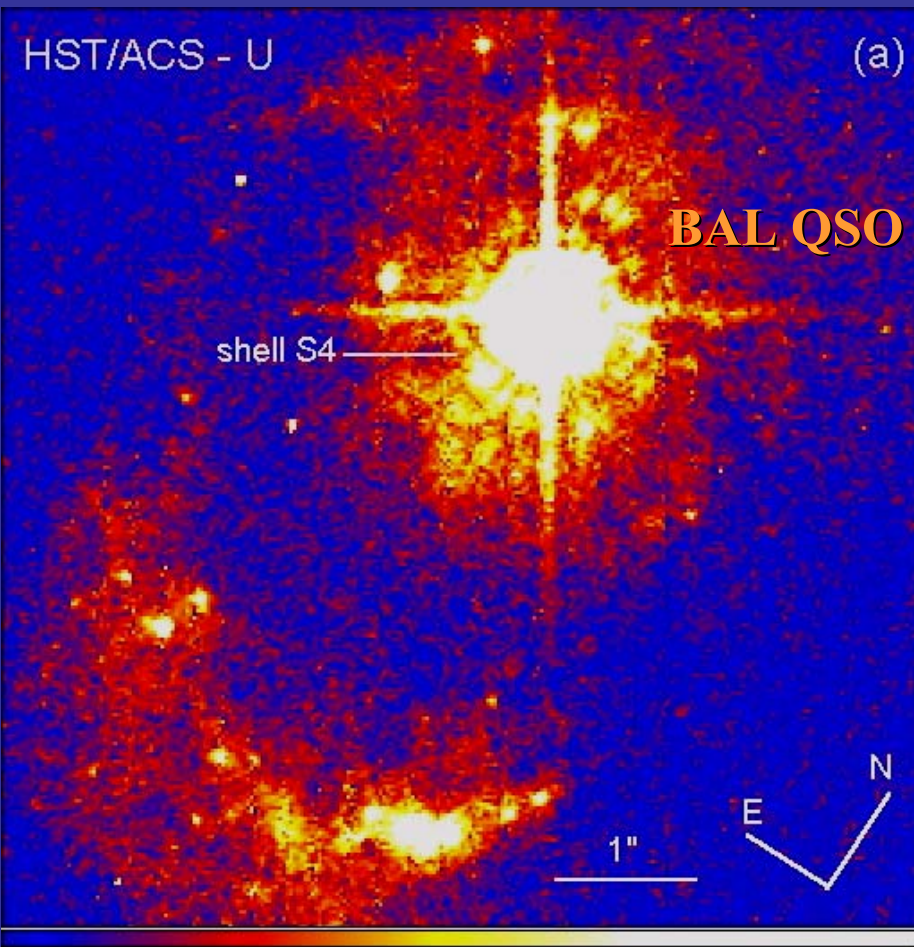

(Lipari et al. 2005, 2006)

Shell S1 (Knot K14-East) Rupture

Espectros Shell S1: WR

Cinematica 3D

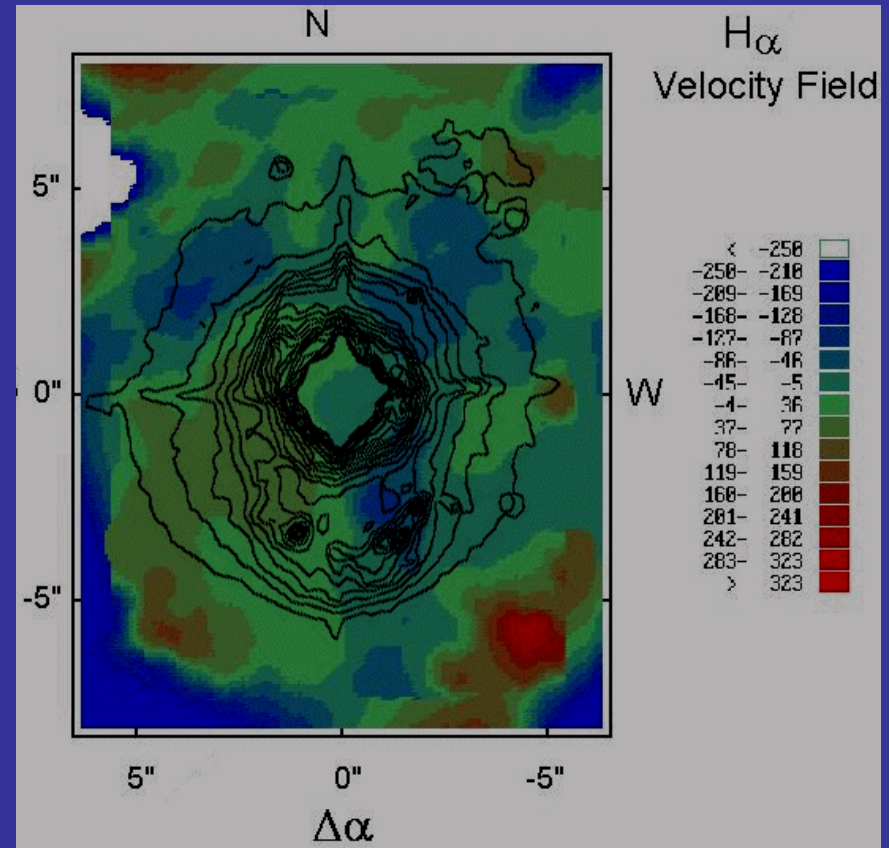
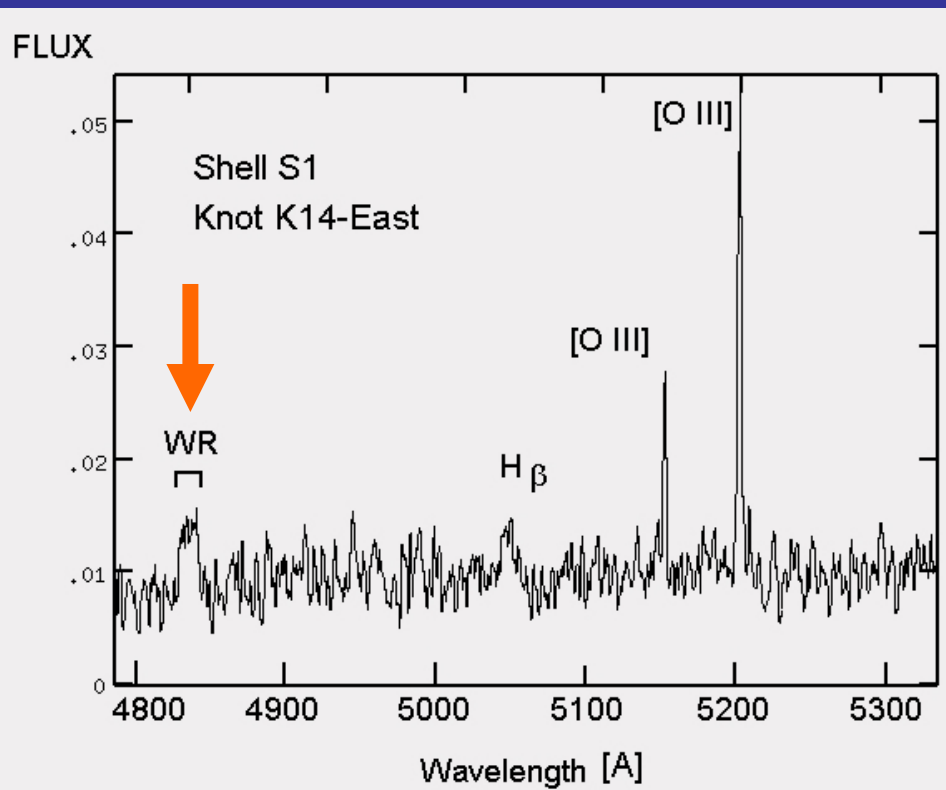

Spectra of Mrk 231 + SN 1979c

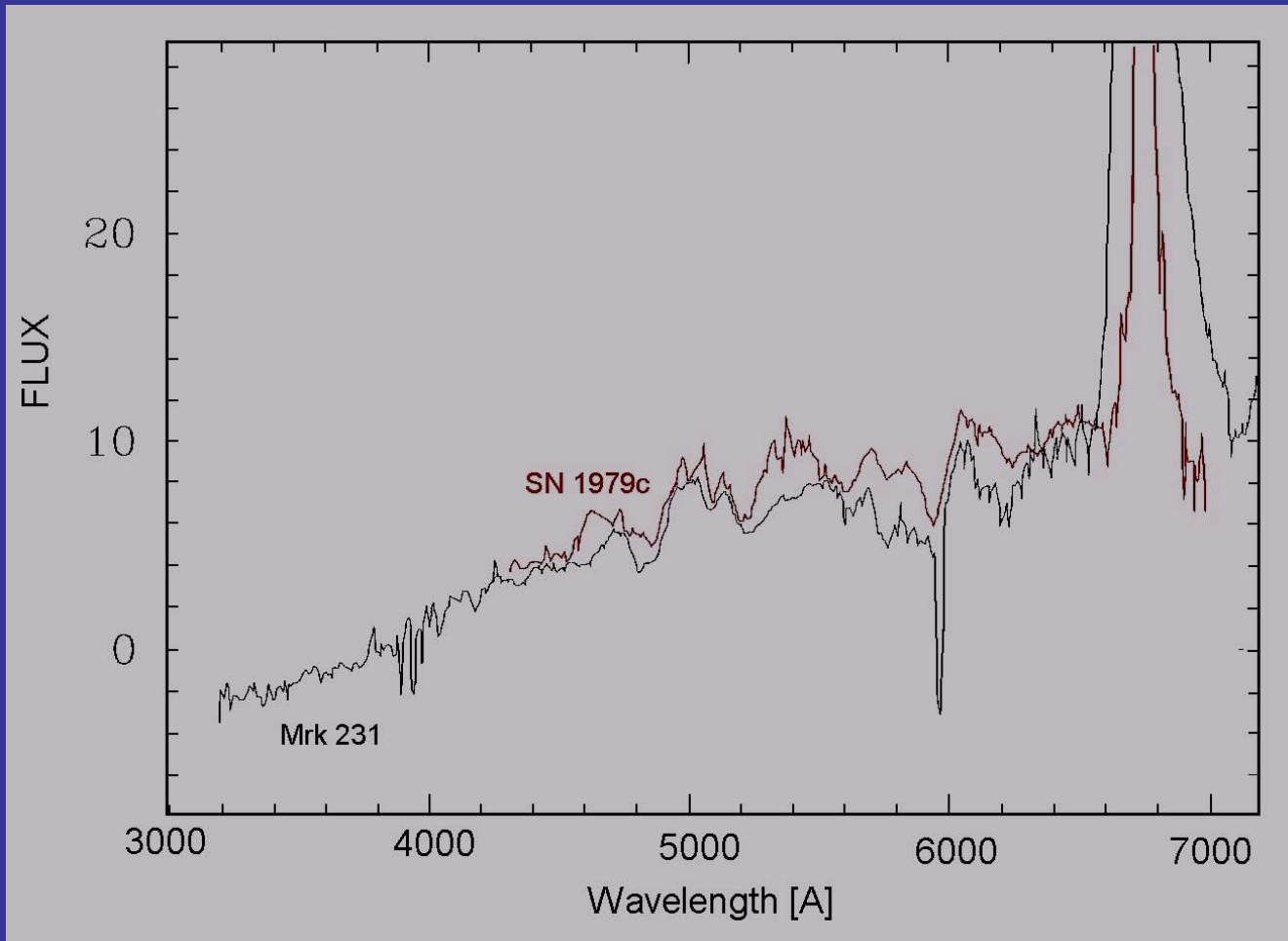

BLR: consistent with ionization by OF process

BAL Systems I, II and III

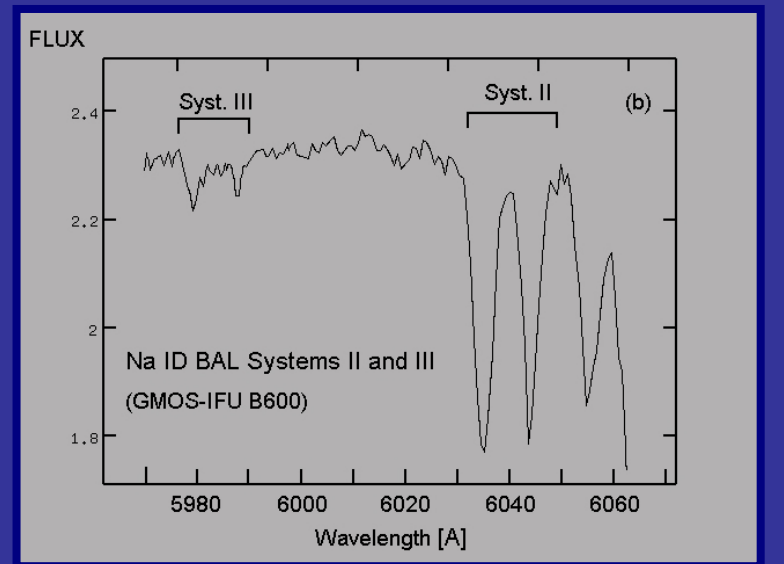
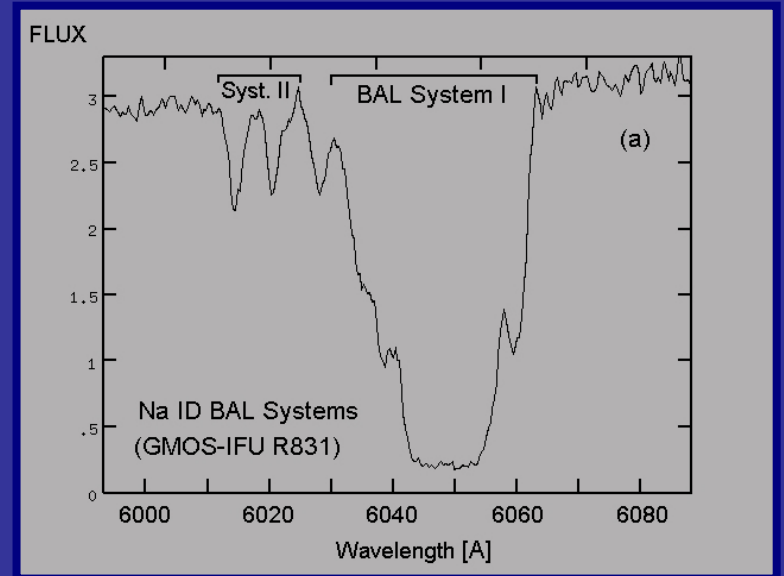
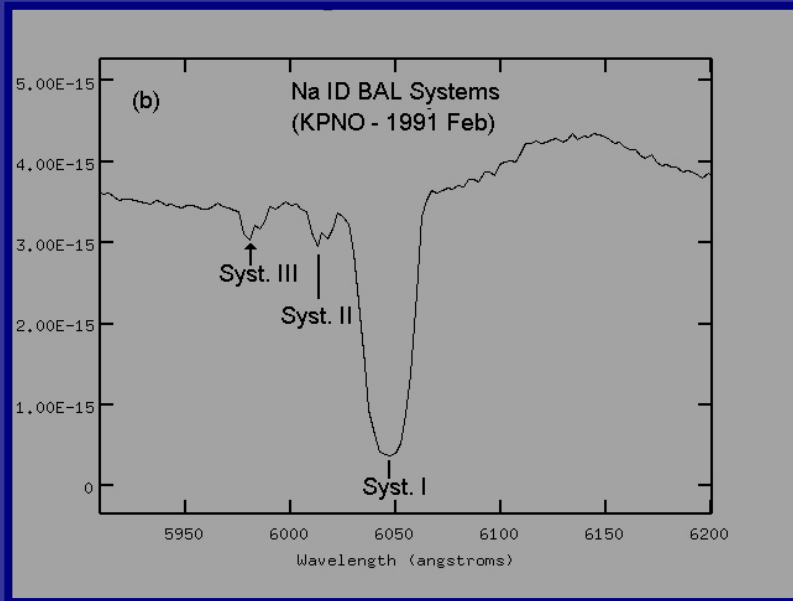

Variability of the BAL System III (Na ID)

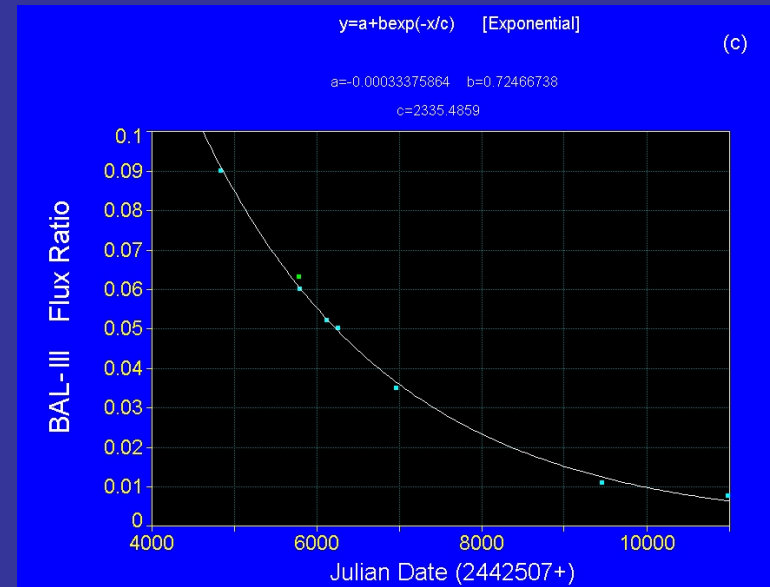
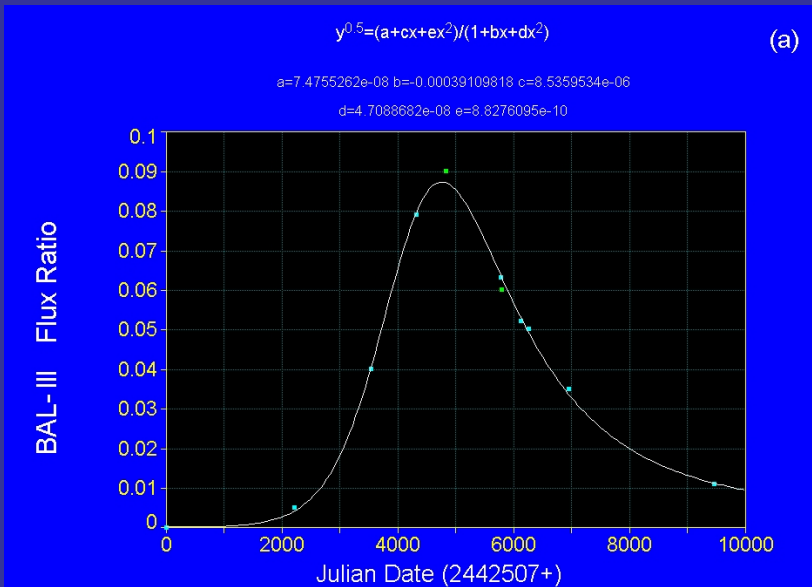
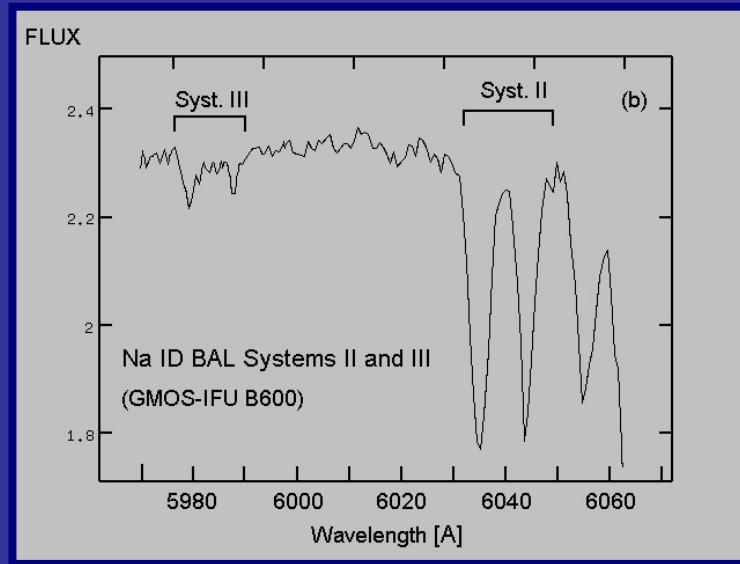

Galfit-3D

Model

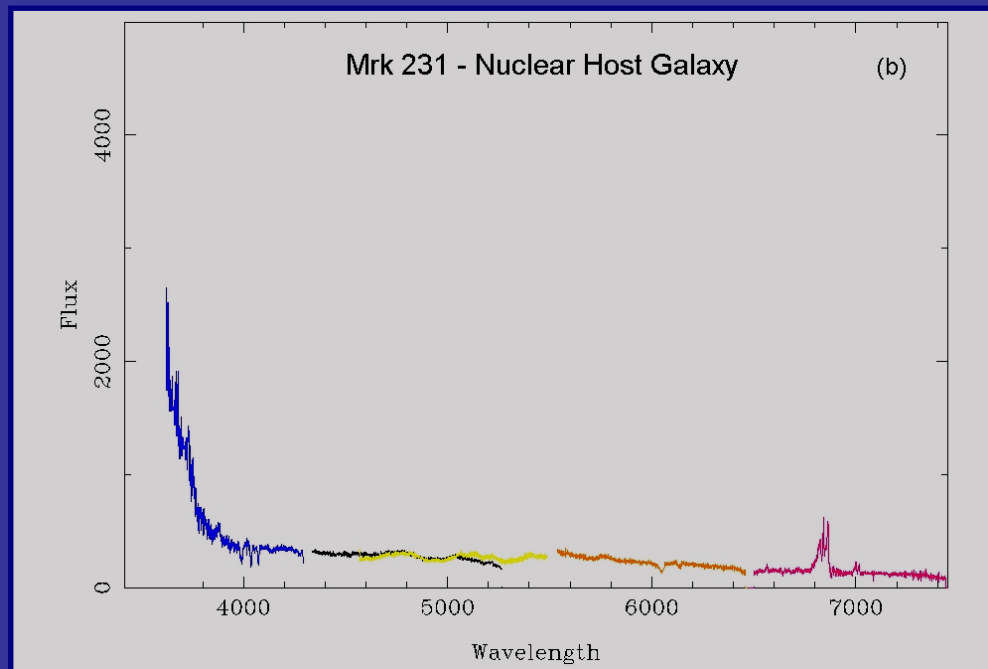
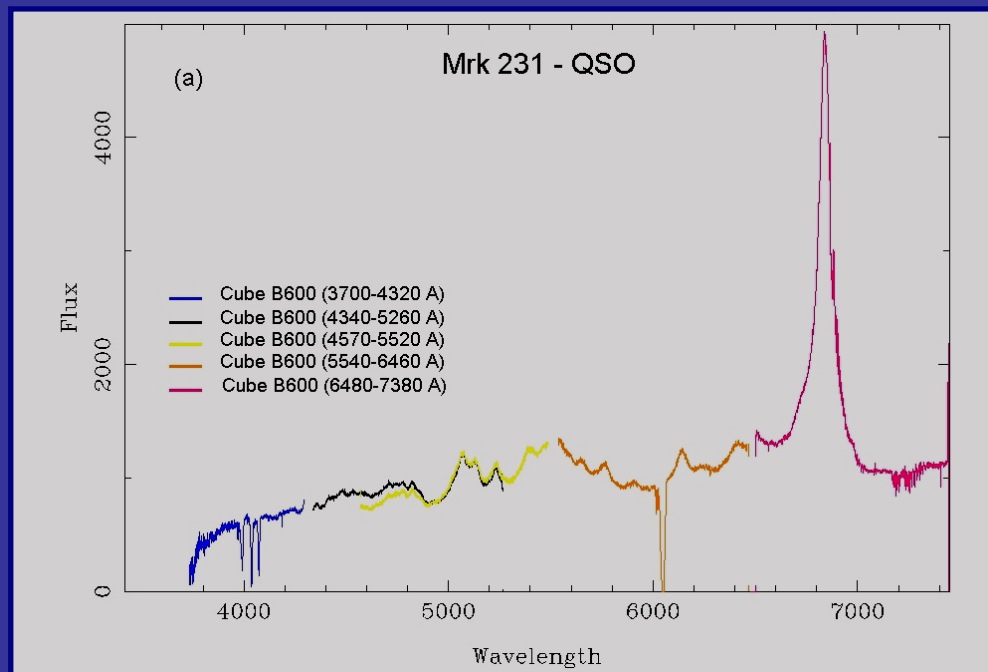

Kinematic of the Stars

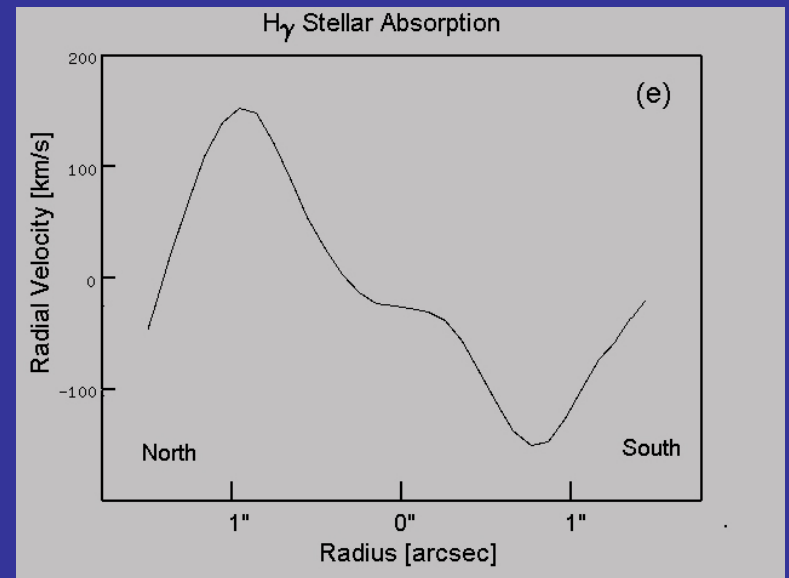
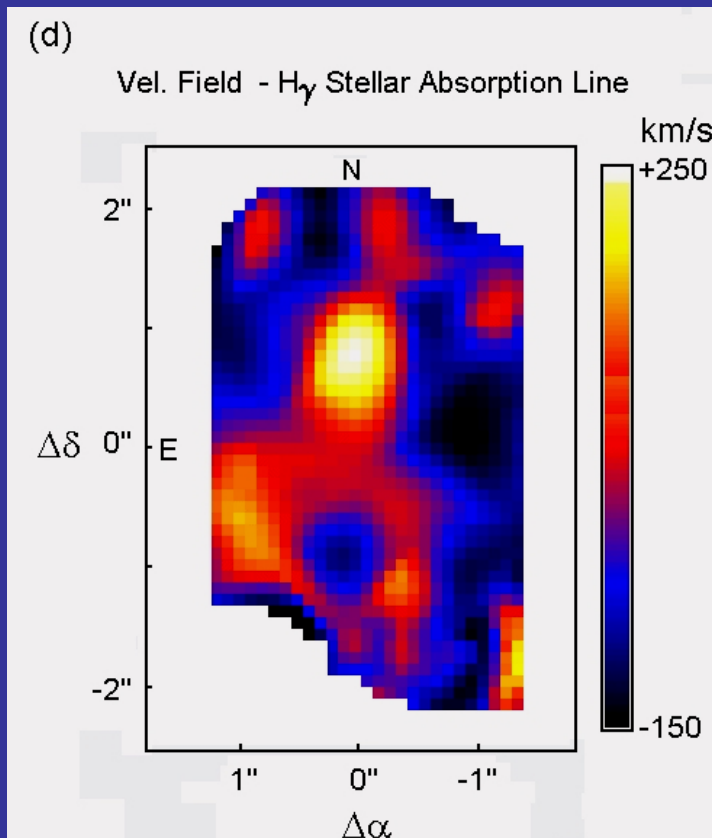

$$M(\text{nuc}) = 0.9 \times 10^{10} M_{\odot}$$

New BAL + IR + Fe II QSO (from the IR-Colors Diagram)

IRAS 04505-2958

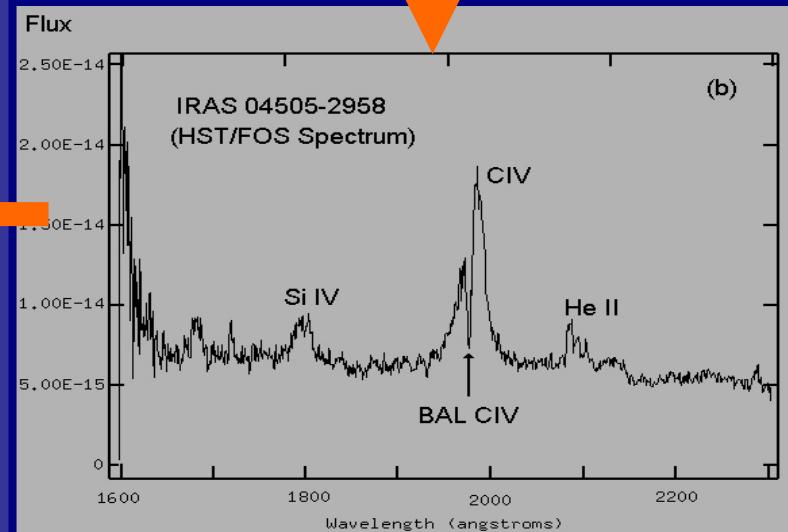
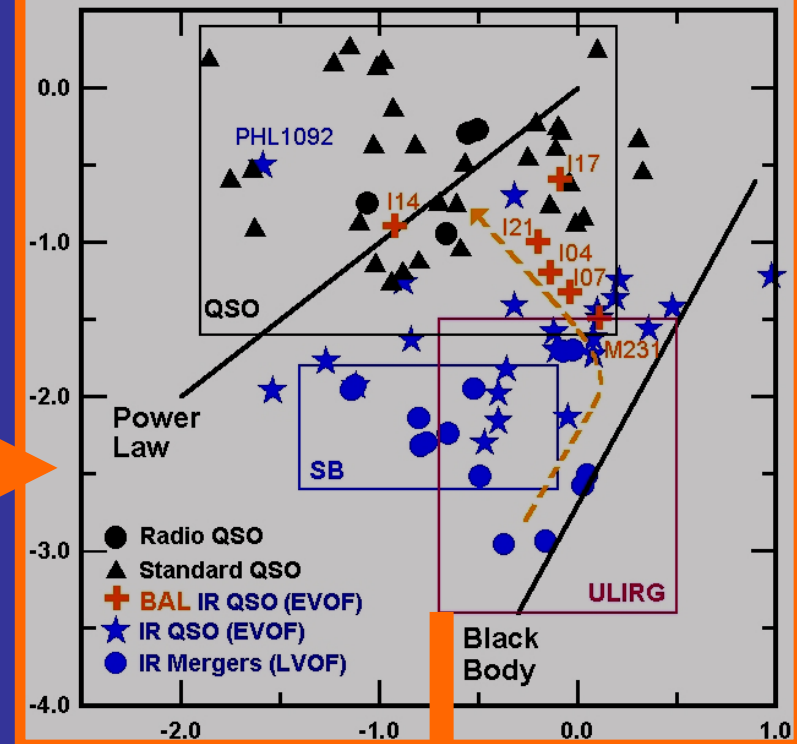
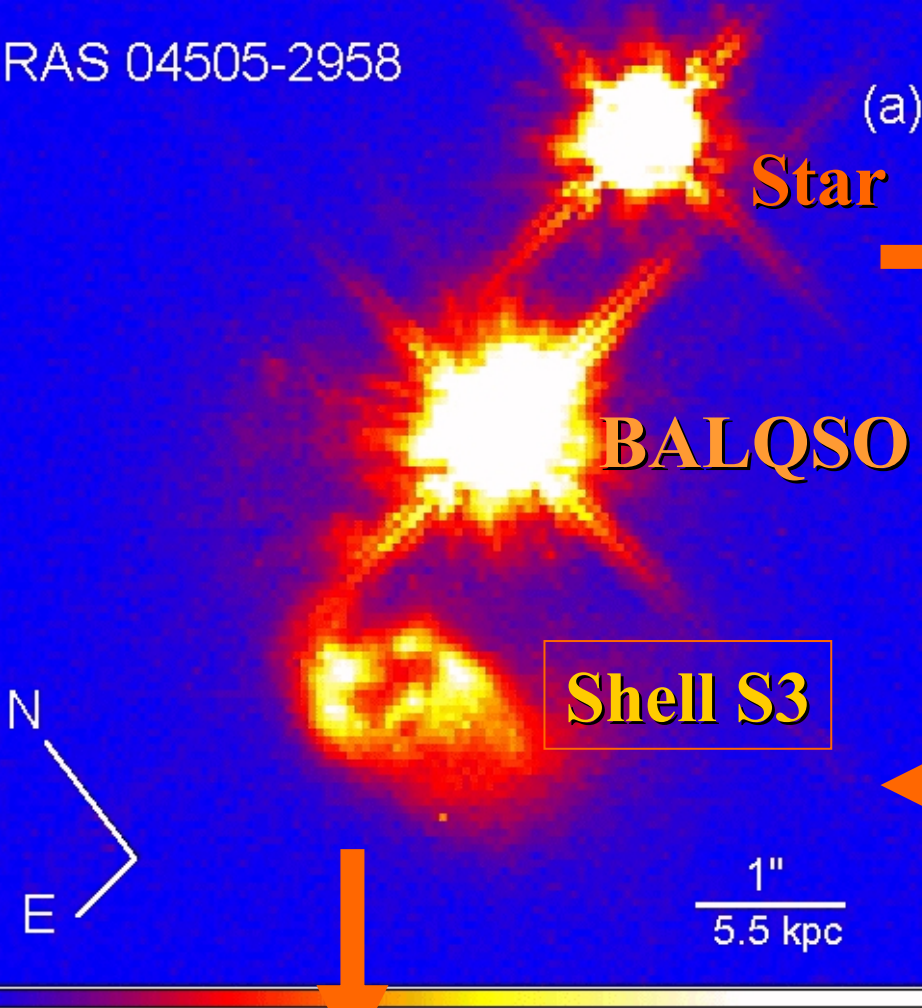

4 MODELS:

(1) Interaction of Galaxies

(2) Hyperwind + Hypershell Galaxy

(3) Naked QSO

(4) Ejected QSO

Gemini + HST Data of the Shells S1, S2, S3

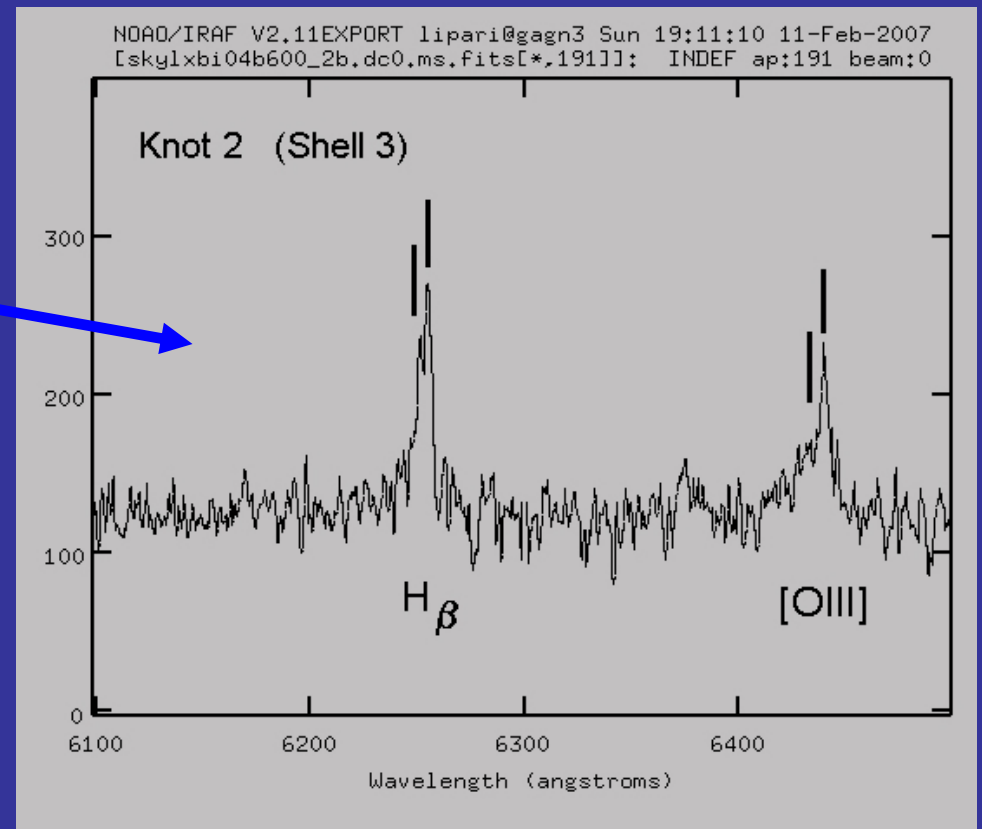
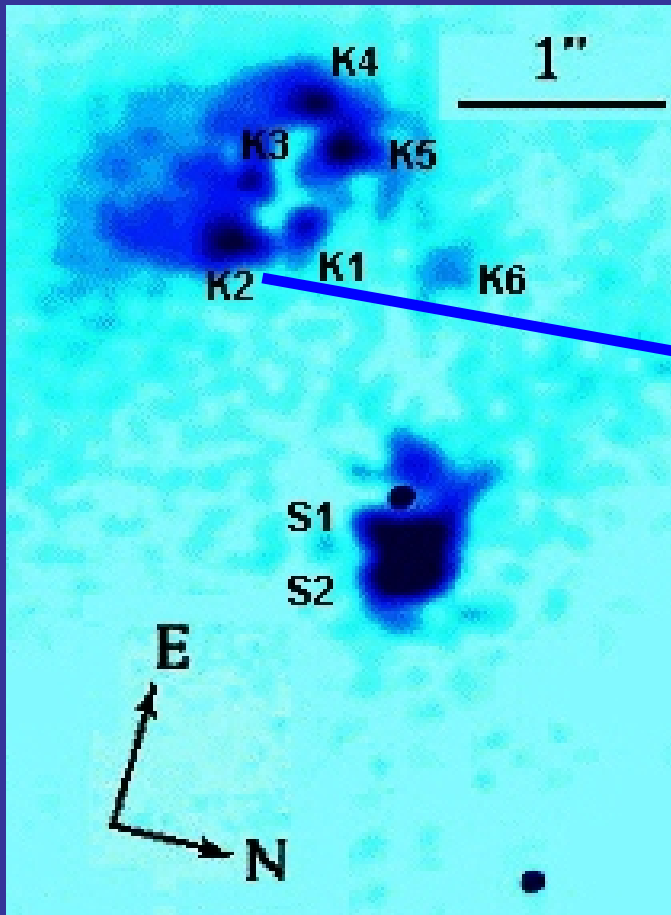

Ly α BLOBS

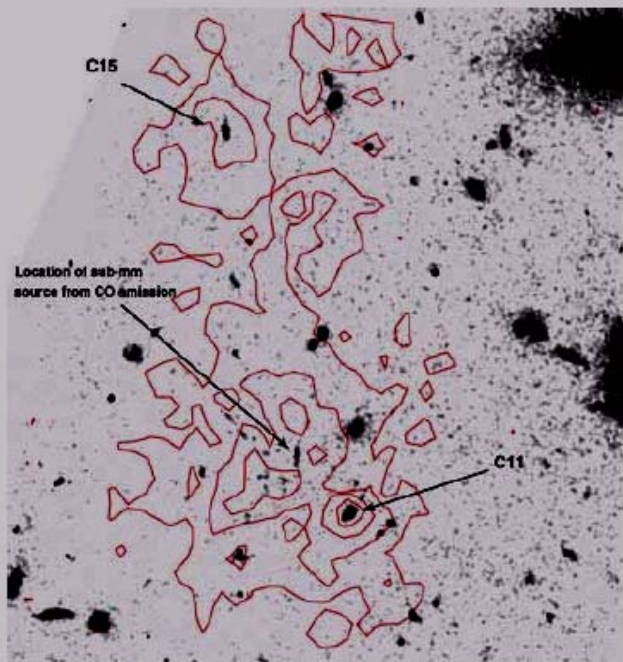
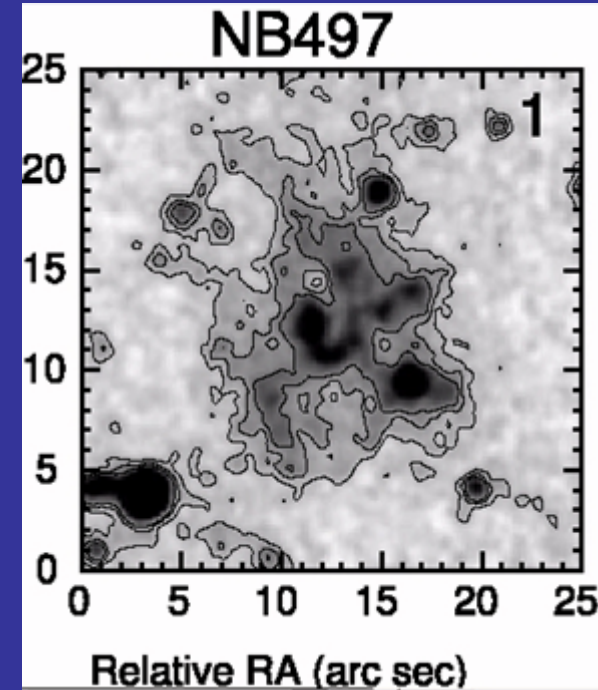
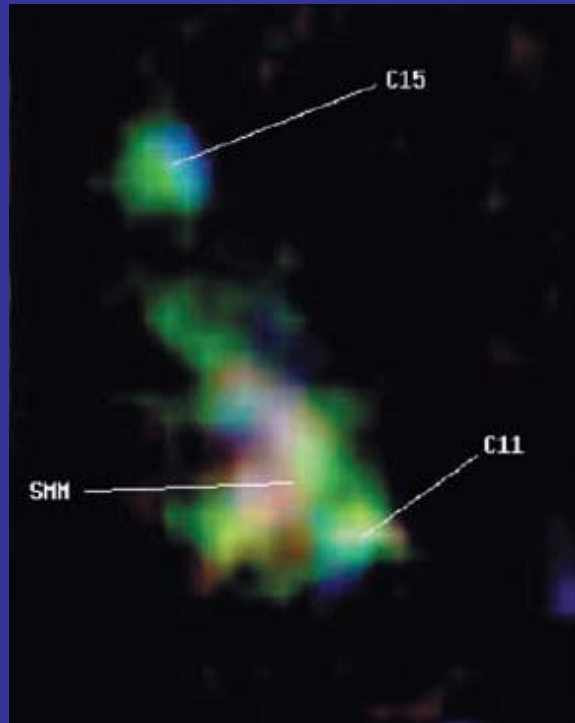

Figure 5. A deep *HST* image of the SSA 22 LAB1 region showing the



Chapman et al. (2004)

Steidel et al(2000)

Taniguchi et al(2000)

SN 2006gy

The most powerful SN ever detected

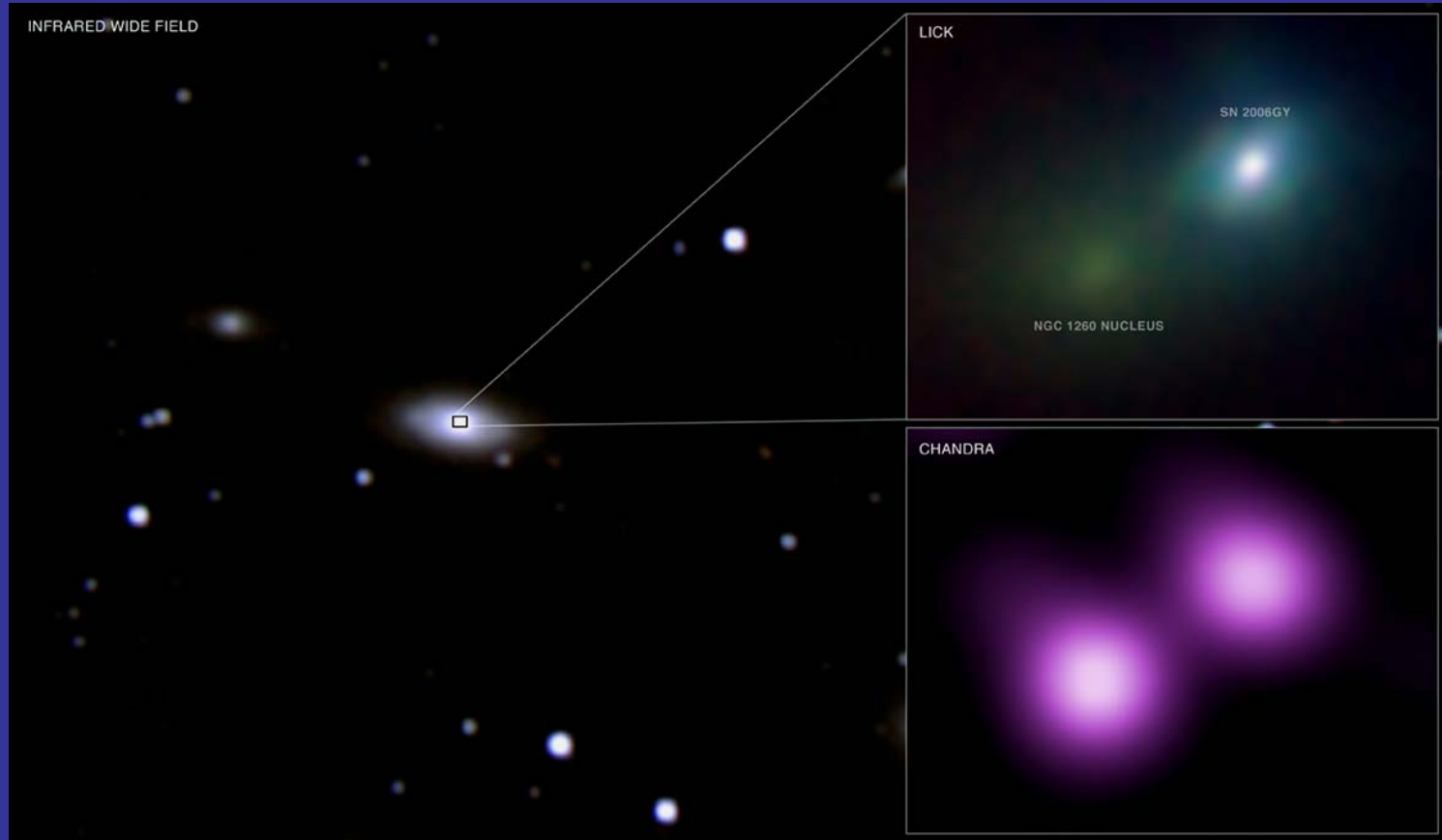

Smith et al. (2007)

SN 2006gy

The most powerful SN ever detected

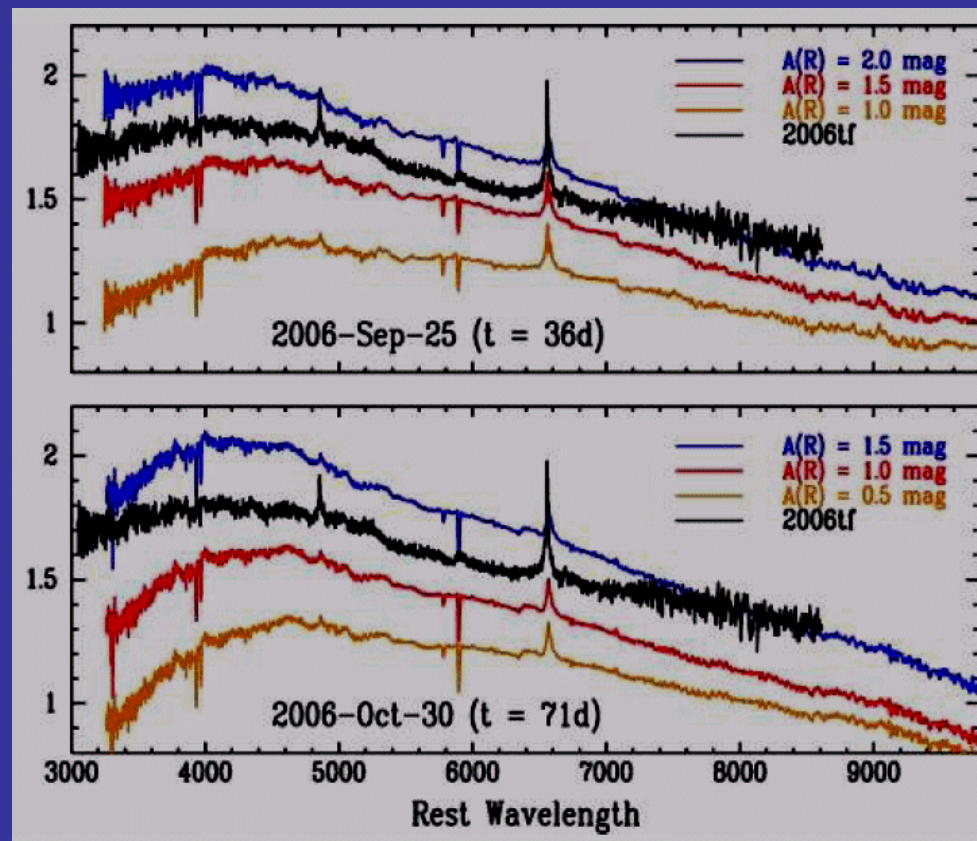
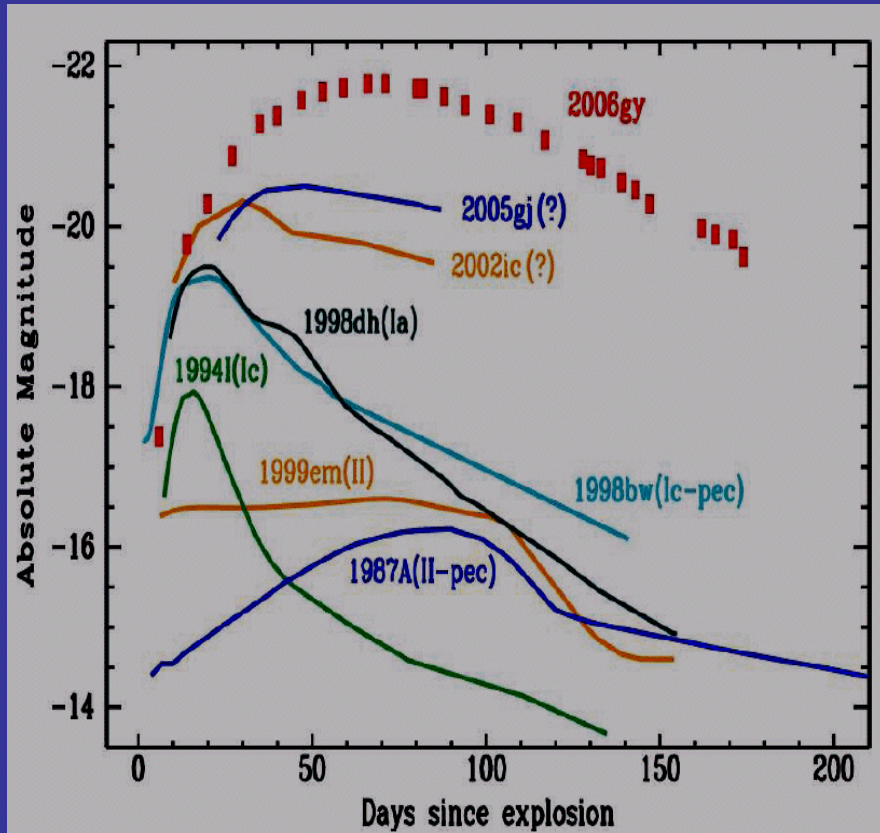

Smith et al. (2007)

IR Merger with OF NGC 2623

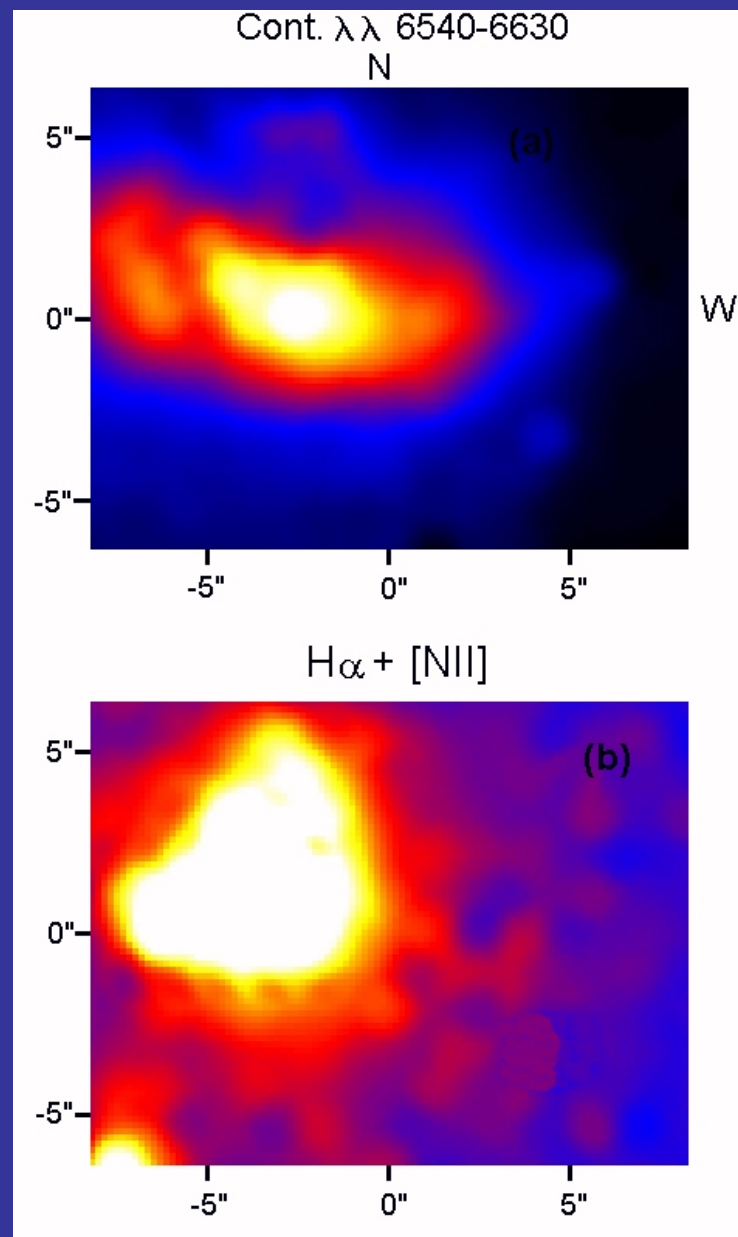
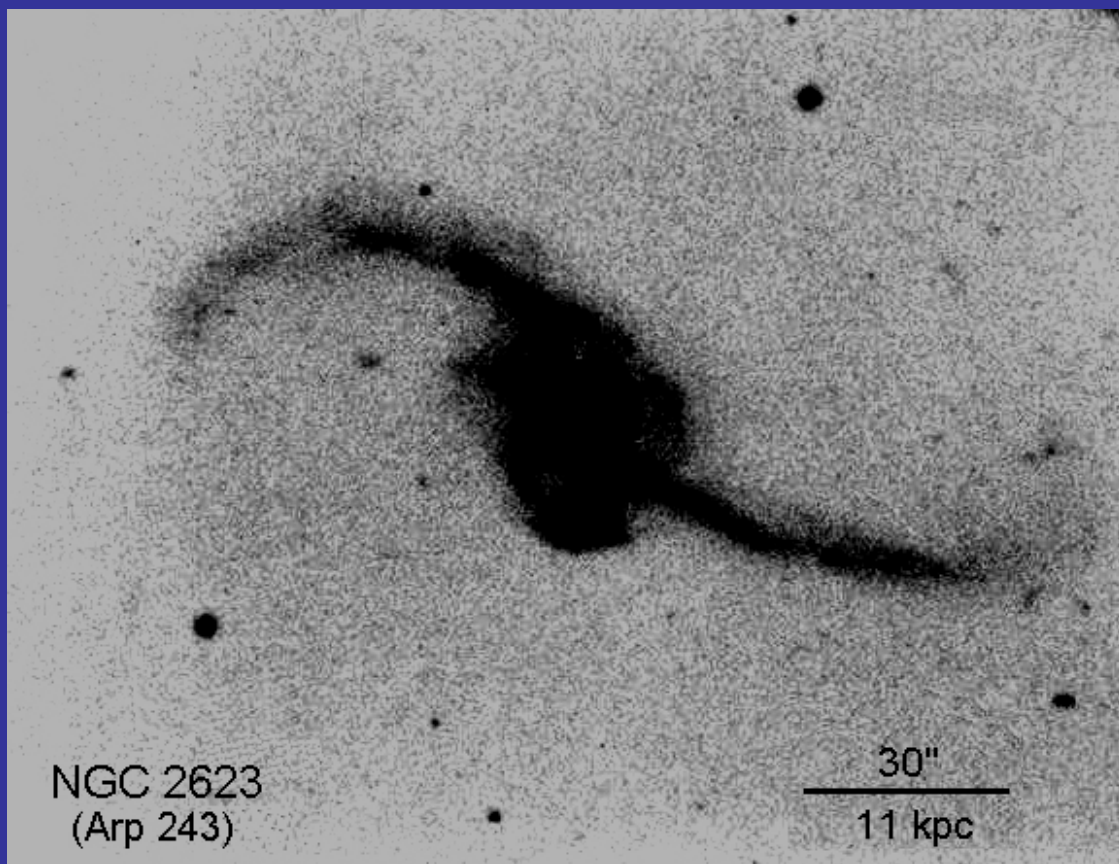

IR Merger with OF NGC 2623

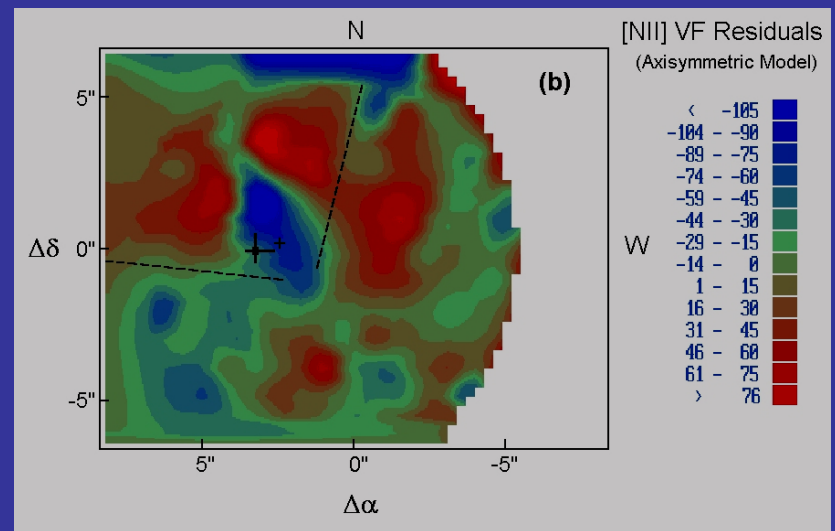
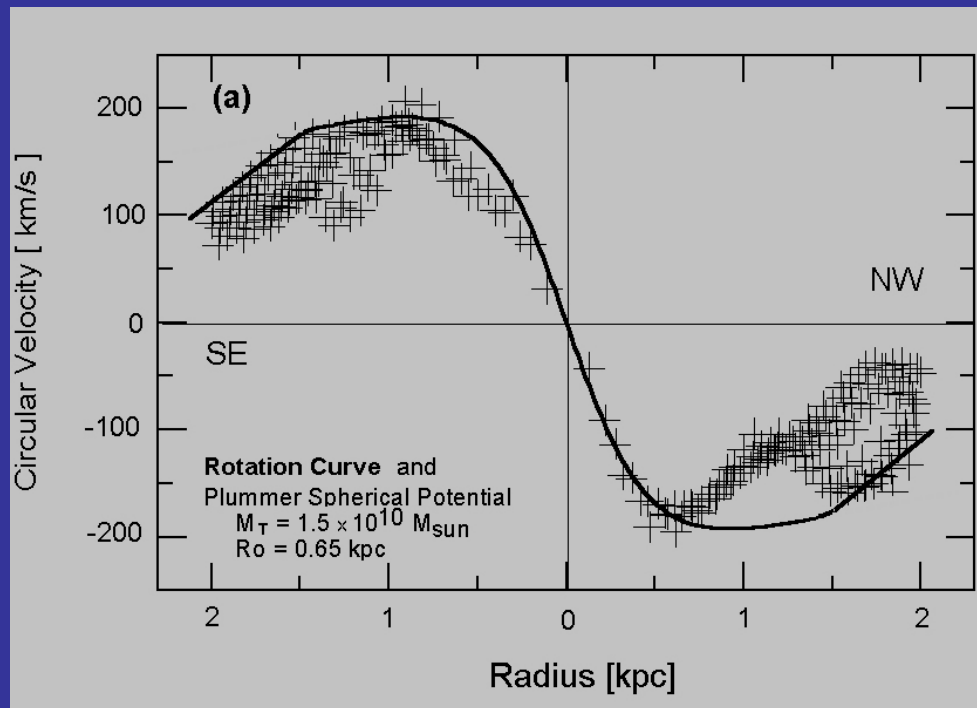
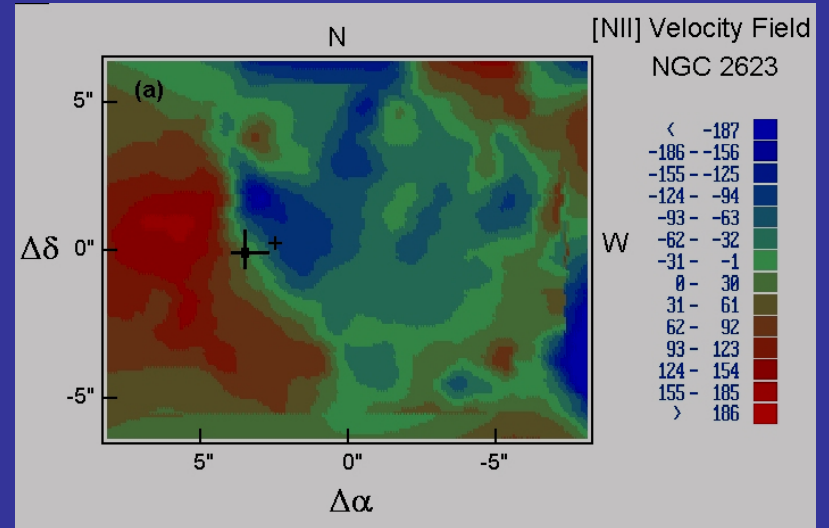

IR Merger with OF NGC 3256

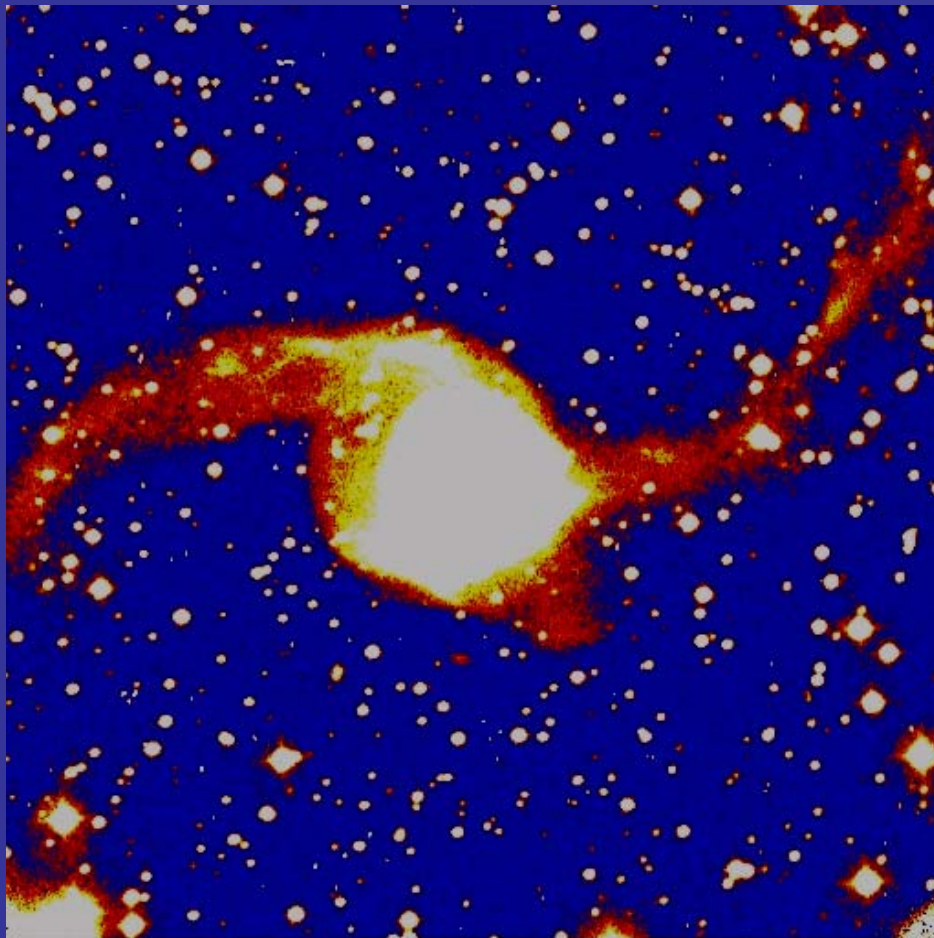

Lipari et al. (2000, 2004)

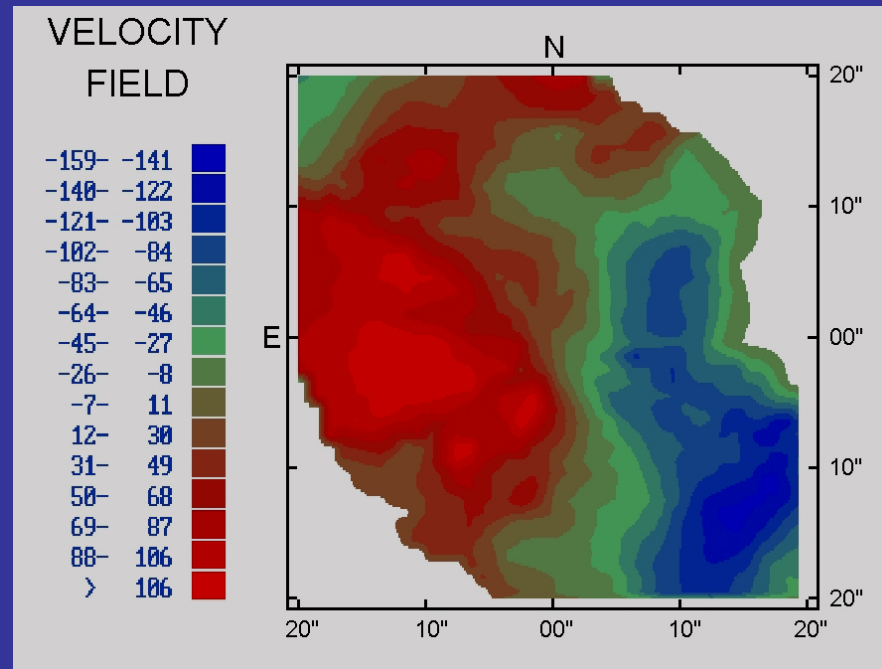

IR Merger NGC 3256

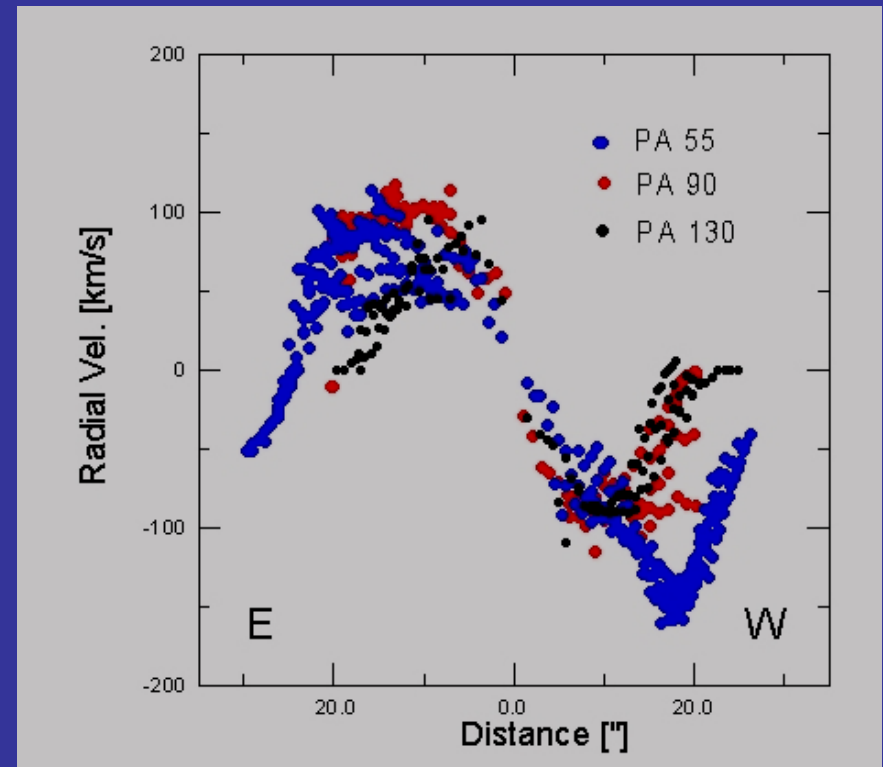
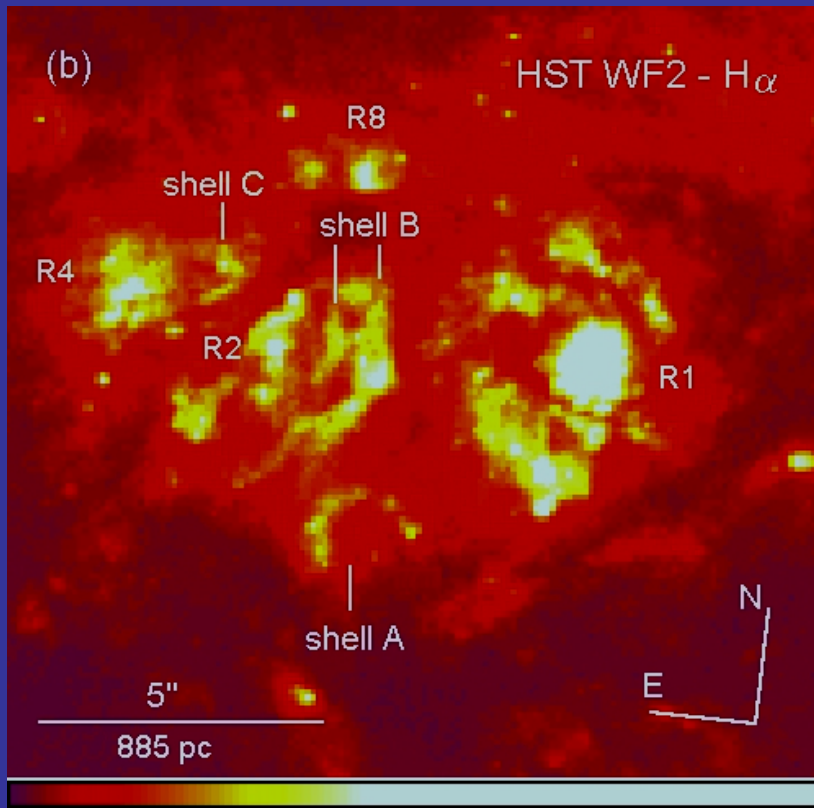

Lipari et al. (2000, 2004)

**El Universo EXPLOSIVO/ACTIVO
(y el Cosmos/Kosmos)**

(VII) EI COSMOS y el KOSMOS

History of the Universe

simplicity

time

complexity

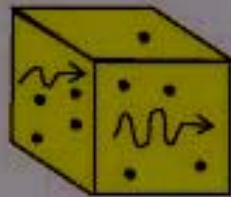

...

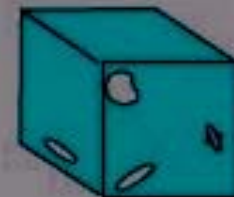
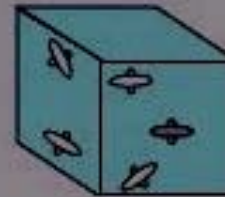
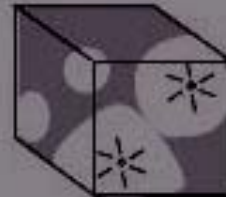

$t \sim 0$

$z = 10^3$

$z \sim 10$

$z \sim 3$

$z \sim 0$

inflation

recombination

reionization
first stars and quasars

galaxy formation

Intelligent life



Big-Bang
Nucleosynthesis



COBE
MAP, Planck

DARK AGES



RENAISSANCE OF
ENLIGHTENMENT



$z \sim 5$

EXISTING
TELESCOPES

Loeb (2000)

The Solvay Congress of 1927

Werner Heisenberg

Louis de Broglie

Erwin Schrödinger



H. A. Lorentz

Max Born

Max Planck

Einstein

Niels Bohr

Que es el tiempo?
Que es la materia?
Que es una ley fisica?
Que es la vida?
Que es la ciencia?
Que es la guerra?

COSMOS

KOSMOS

**FISICO
(Insensible)**

FISICO

BIOLOGICO

PENSAMIENTO

CONCIENCIA

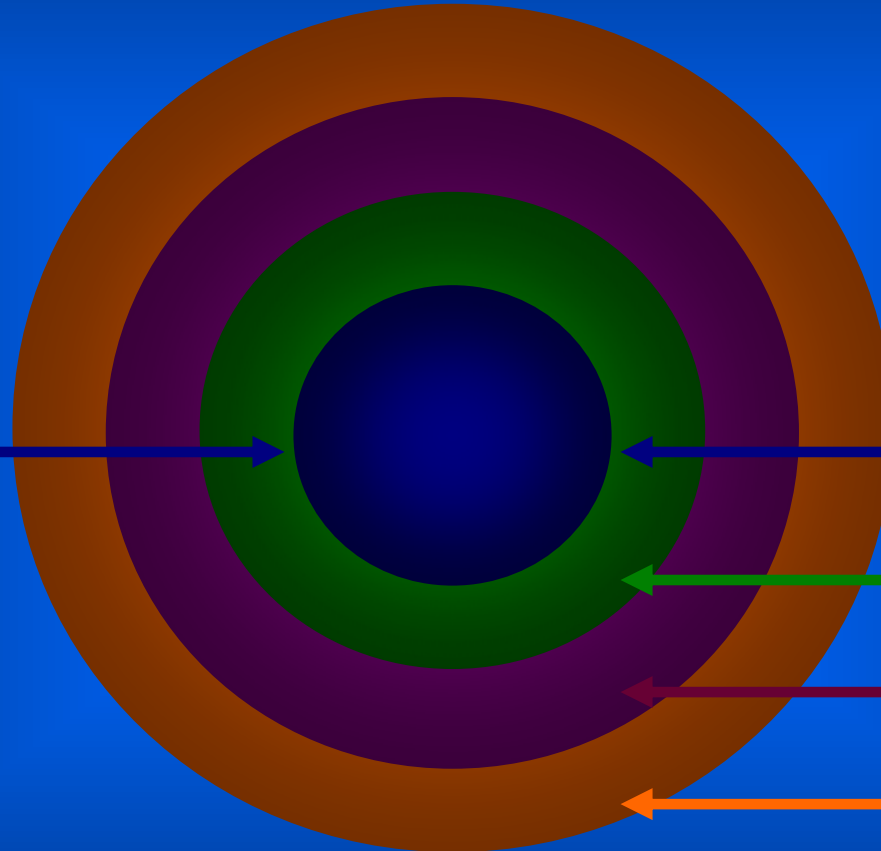

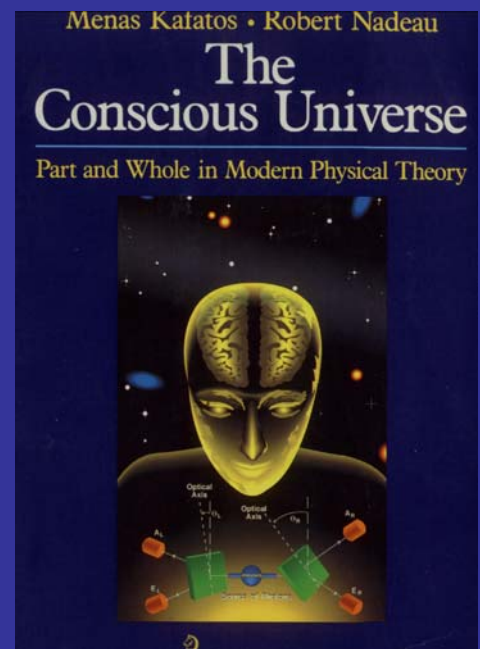
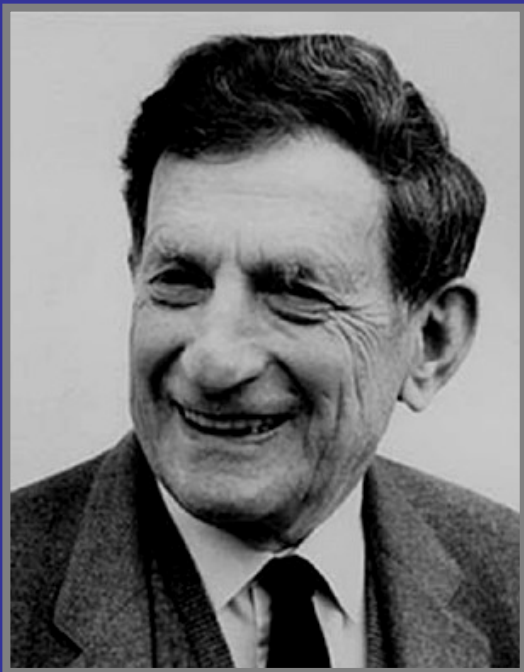

MECANICA CUANTICA:

Perfecciono el experimento EPR, base del Teorema de Bell (sobre la no localidad de las leyes físicas).

MODELO DEL FUNCIONAMIENTO DEL CEREBRO

LA TOTALIDAD y el Orden Implicado

David Bohm

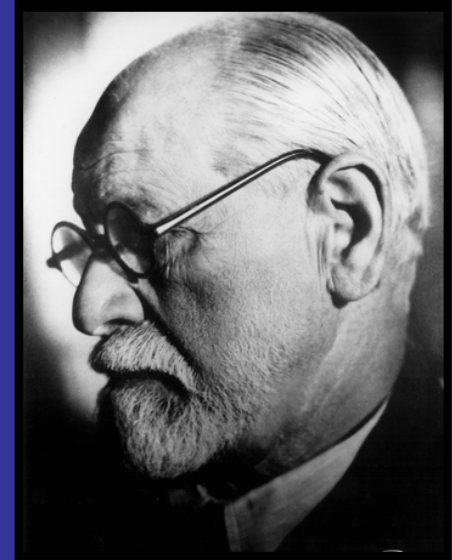

“Los Pensamientos y las Conductas, se forman y condicionan (en parte) en el Inconciente y las Experiencias de Vida.

Solo me siento identificado con el pensamiento de los Antiguos Gnosticos”.

Carl G. Jung

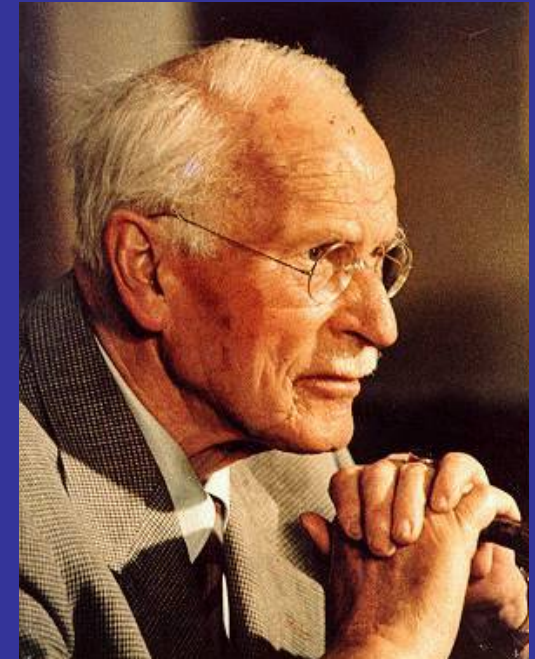

CAMPOS MORFICOS:

“Basicamente, consiste en el hecho que lo aprendido por un individuo de una especie, se trasmite a toda la especie”.

Es una extension a biologia del Inconciete Colectivo (de G. C. Jung).

Sheldrake

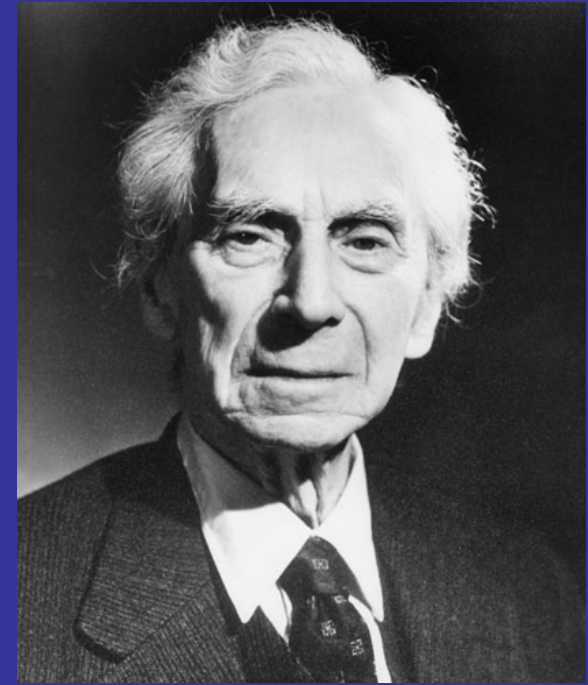

“Los logros científicos, deberían ser utilizados para la Felicidad Humana. Mi larga experiencia con estadistas y gobiernos (grupos de poder) me ha tornado algo esceptico.

Aun esta por verse si la ciencia actual es una bendicion o una maldicion para el genero humano”.

Bertrand Russell

(Matemático y Filósofo, Premio Nobel de Literatura)

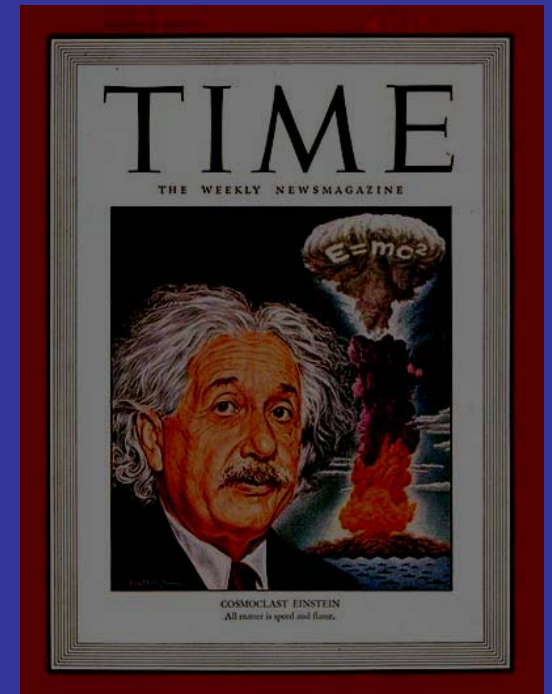
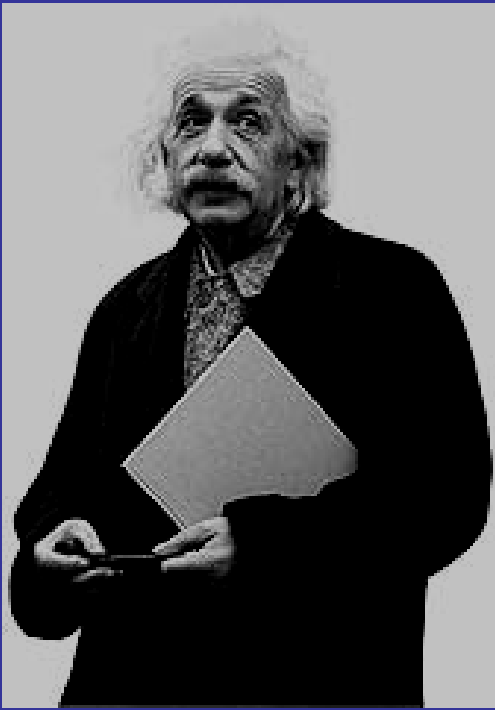

“Si bien generalmente ciencia y espiritualidad tienen intereses diferentes, a veces me pregunto que motivo a Kepler, Galileo y Newton en su búsqueda de las leyes de la Mecánica Celeste. Creo que fue un profundo sentimiento cósmico espiritual.

La Mística es la emoción más hermosa que podemos experimentar. Y es el fundamento de toda ciencia y arte”.

A. Einstein

Efecto de Bomba Napalm en Vietnam

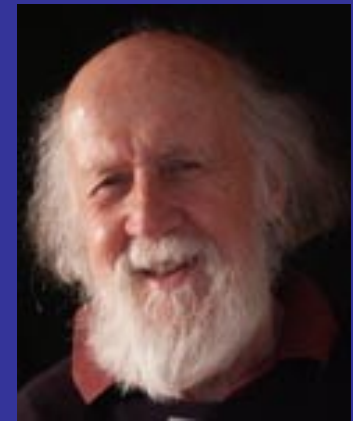



Detalles de Efecto del Napalm en Vietnam

**“Primero se llevaron a los comunistas, NO me importo porque yo no lo era.
Enseguida se llevaron a unos obreros, NO me importo porque yo no lo era.
Despues detuvieron a unos curas, NO me importo porque no soy religioso.**

AHORA ME LLEVAN AMI, PERO YA ES TARDE!.

“Bertolt Bretch”





“Creamos una alienación de nosotros mismos, de los demás y del mundo al fracturar nuestras experiencias por fronteras artificiales. Cada frontera es una limitación de la Conciencia”

“La Historia de la Evolución, es la Historia de la Evolución de la Conciencia”

“Una verdadera Teoría del Todo no puede dejar afuera las actividades más bellas del ser humano: el arte, la filosofía, ... la espiritualidad”.

